



GENERAL OSCILLATOR SPECIFICATION : TS05

Frequency Range	: 10.000 000 to 52.000 000 MHz.
Frequency Stability	
with Temperature (Maximum) ^{*1}	: ± 0.1 to ± 0.28 ppm dependant on Operating Temperature Range.
with Supply Voltage (Maximum for a 5.0 % change)	: ± 0.05 ppm.
with Load (Maximum for a 10.0 % change)	: ± 0.05 ppm.
with Aging (Maximum per year)	: ± 0.5 ppm.
Calibration (at + 25.0 °C)	
1 hour after reflow (Maximum)	: ± 1.5 ppm.
Frequency Adjustment (option)	(over voltage control range applied to Pin 1)
Frequency Range	: ± 3.0 ppm to ± 15.0 ppm.
Voltage Control Range	: + 0.5 to + 2.5 V.
Slope	: Positive, increasing control voltage increases output frequency.
Linearity (Maximum)	: 1.0 %.
Input Impedance (Minimum)	: 0.1 MΩ.
Temperature Range	
Operating	: - 10 to + 70 °C (- 40 to + 85 °C plus other options).
Storage	: - 40 to + 85 °C.
Supply Voltage (± 5.0 %)	: + 3.0 V.
Supply Current (at 26.0 MHz) (Maximum)	
CMOS	: 4.0 mA.
Clipped Sinewave	: 2.0 mA.
Output Characteristics	
CMOS	
Waveform	: Squarewave.
Output	: CMOS.
Load	: 15 pF.
Mark Space Ratio (at 1/2 V _{CC})	: 55:45 to 45:55.
Rise / Fall Times (Maximum)	: 10.0 ns.
Logic Levels	
High (Minimum)	: 0.9 V _{CC} .
Low (Maximum)	: 0.1 V _{CC} .
Clipped Sinewave	
Waveform	: Clipped Sinewave.
Output (Minimum peak to peak)	: 0.8 V.
Load (± 10.0 %)	: 10 kΩ // 10 pF.
Start up Time (Maximum)	: 10.0 ms.
Pin 6 (Tri-State)	
High (≥ 70 % V _{CC}) or Open	: Enable.
Low (≤ 30 % V _{CC})	: Disable.
Package Style	: 5.00 x 3.20 x 1.50 mm.
Marking	
Line 1	: PDI
Line 2	: Spec. code
Phase Noise (at 26.0 MHz) (Typical)	
100.0 Hz	: 117 dBc / Hz.
1.0 kHz	: 138 dBc / Hz.
10.0 kHz	: 152 dBc / Hz.

Notes

- *1 ± 0.1 ppm is not available for CMOS output.
- Terminals to be Au.
- All product supplied in anti-static packaging.
- All product is supplied RoHS compliant.
- Product can be supplied on Tape and Reel, on reels of 1,000 units.
- Specifications subject to change without notice.



GENERAL OSCILLATOR SPECIFICATION : TS05



Package Drawing

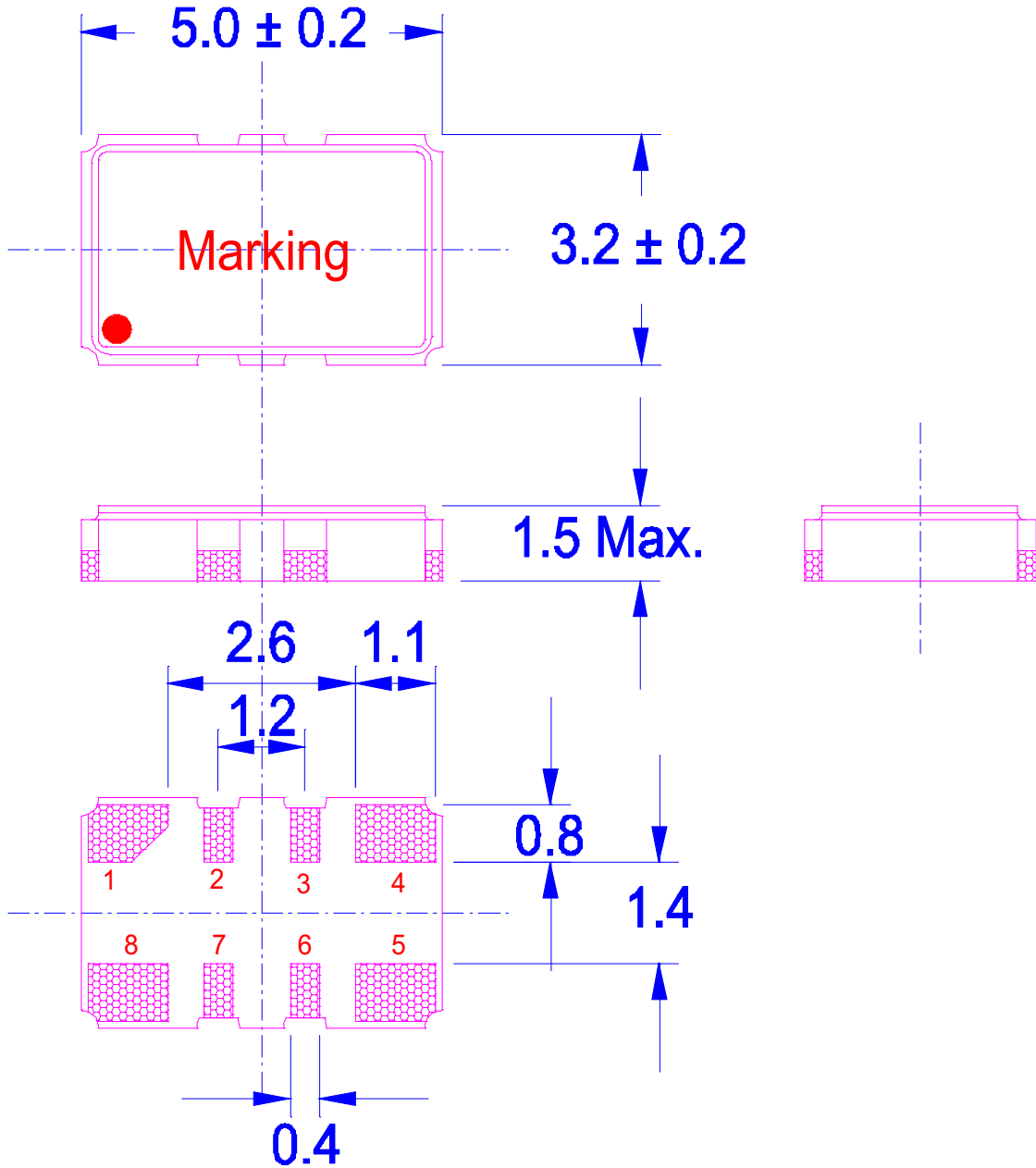

Pin Connections

All Dimensions and Tolerances are in mm

- 1 VCTCXO Voltage Control
- TCXO Ground
- 2 Not Connected
- 3 Not Connected
- 4 Ground
- 5 Output
- 6 Tri-State
- 7 Not Connected
- 8 Supply Voltage



GENERAL OSCILLATOR SPECIFICATION : TS05



Solder Pattern (Reference purposes only)

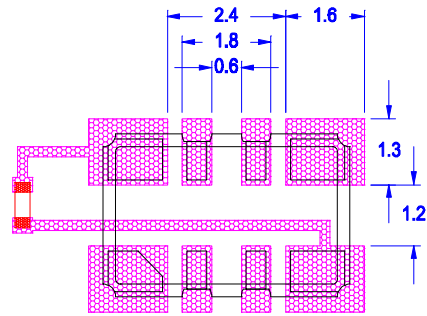

It is recommended that a 10 nF bypass capacitor should be placed between the Supply and Ground Pins to minimise power supply line noise.

Reflow Solder Profile

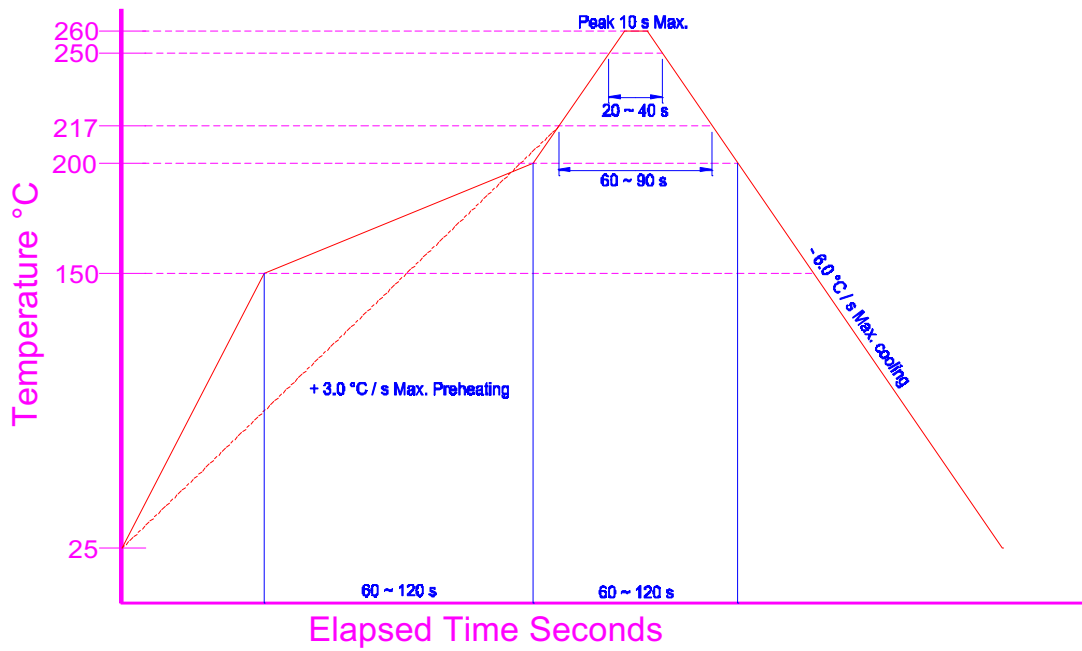



GENERAL OSCILLATOR SPECIFICATION : TS05



Tape & Reel Dimensions

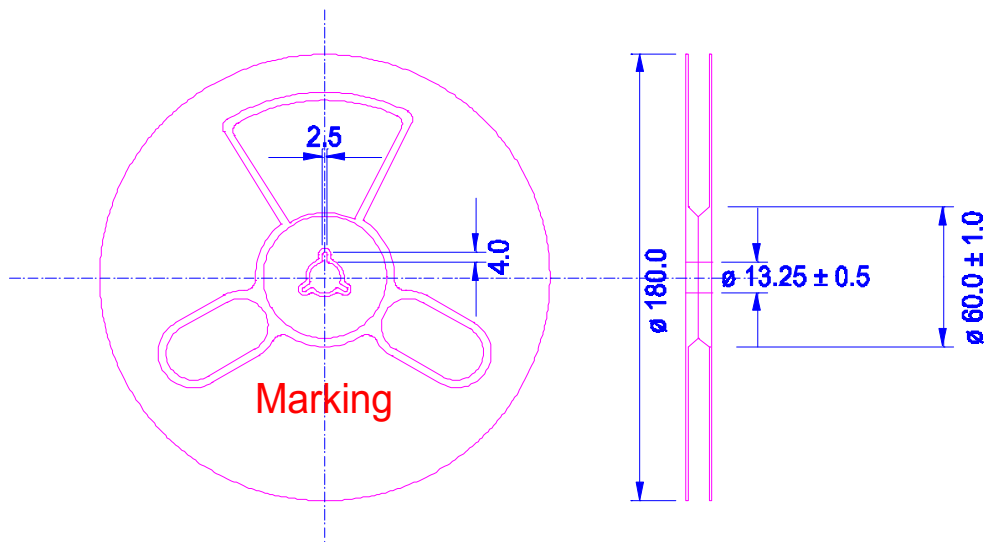
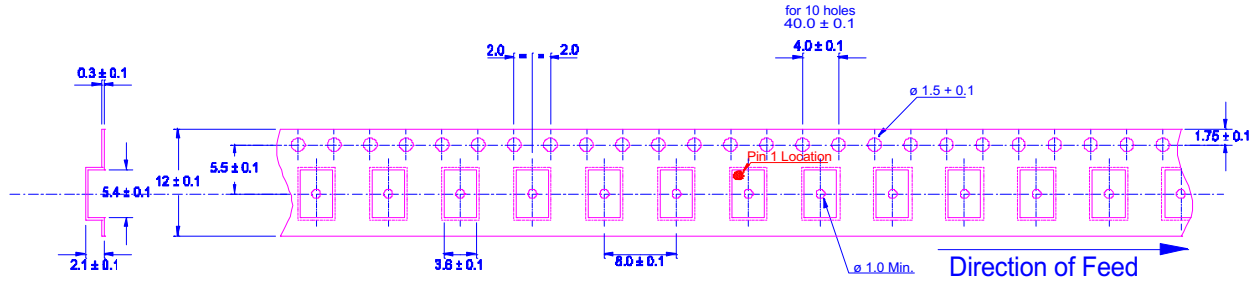

Empty Pockets

- Trailing end (Minimum) : 200 mm.
- Leading end (Minimum) : 400 mm.