



STAC3932B

RF power transistors HF/VHF/UHF N-channel MOSFETs

Target Specification

Features

- Excellent thermal stability
- Common source push-pull configuration
- $P_{OUT} = 580\text{ W typ.}$
with 24.6 dB gain @ 123 MHz
- In compliance with the 2002/95/EC
European directive

Description

The STAC3932B is a gold metallized N-channel MOS field-effect RF power transistor. It is intended for use in 100 V DC large signal applications up to 250 MHz.



Figure 1. Pin connection

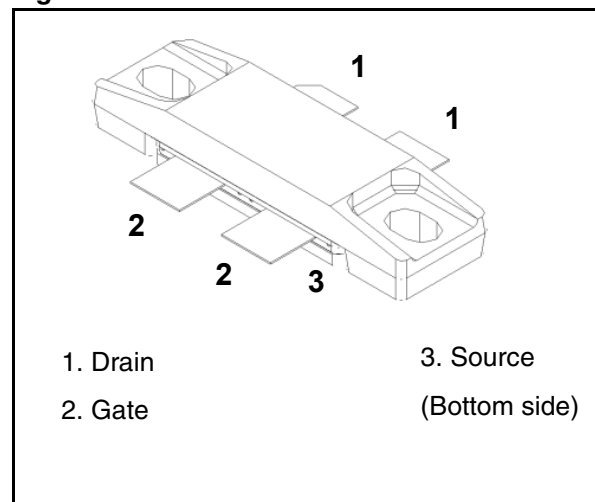

Table 1. Device summary

Order code	Marking	Package	Packaging
STAC3932B	STAC3932	STAC244B	Plastic tray

Contents

1	Electrical data	3
1.1	Maximum ratings	3
1.2	Thermal data	3
2	Electrical characteristics	4
2.1	Static	4
2.2	Dynamic	4
3	Impedance	5
4	Electrical schematic and BOM	6
5	Circuit layout	8
6	Typical performance	9
7	Package mechanical data	12
8	Revision history	14

1 Electrical data

1.1 Maximum ratings

Table 2. Absolute maximum ratings ($T_{CASE} = 25^{\circ}C$)

Symbol	Parameter	Value	Unit
$V_{(BR)DSS}^{(1)}$	Drain source voltage	250	V
V_{DGR}	Drain-gate voltage ($R_{GS} = 1\text{ M}\Omega$)	250	V
V_{GS}	Gate-source voltage	± 20	V
I_D	Drain current	20	A
P_{DISS}	Power dissipation	625	W
T_J	Max. operating junction temperature	200	$^{\circ}C$
T_{STG}	Storage temperature	-65 to +150	$^{\circ}C$

1. $T_J = 150^{\circ}C$

1.2 Thermal data

Table 3. Thermal data

Symbol	Parameter	Value	Unit
R_{thJC}	Junction - case thermal resistance	0.28	$^{\circ}C/W$

2 Electrical characteristics

$$T_{\text{CASE}} = +25\text{ }^{\circ}\text{C}$$

2.1 Static

Table 4. Static (per side)

Symbol	Test conditions		Min.	Typ.	Max.	Unit
$V_{(\text{BR})\text{DSS}}^{(1)}$	$V_{\text{GS}} = 0\text{ V}$	$I_{\text{DS}} = 100\text{ mA}$	250			V
I_{DSS}	$V_{\text{GS}} = 0\text{ V}$	$V_{\text{DS}} = 100\text{ V}$			1	mA
I_{GSS}	$V_{\text{GS}} = 20\text{ V}$	$V_{\text{DS}} = 0\text{ V}$			250	nA
V_{TH}	$I_{\text{D}} = 250\text{ mA}$		2.0		4.0	V
$V_{\text{DS(ON)}}$	$V_{\text{GS}} = 10\text{ V}$	$I_{\text{D}} = 5\text{ A}$		2.5	3.5	V
G_{FS}	$V_{\text{DS}} = 10\text{ V}$	$I_{\text{D}} = 2.5\text{ A}$	3.0		5.0	S
C_{ISS}	$V_{\text{GS}} = 0\text{ V}$	$V_{\text{DS}} = 100\text{ V}$		492		pF
C_{OSS}	$V_{\text{GS}} = 0\text{ V}$	$V_{\text{DS}} = 100\text{ V}$		134		pF
C_{RSS}	$V_{\text{GS}} = 0\text{ V}$	$V_{\text{DS}} = 100\text{ V}$		5.2		pF

1. $T_{\text{J}} = 150\text{ }^{\circ}\text{C}$

2.2 Dynamic

Table 5. Dynamic CW

Symbol	Test conditions	Min.	Typ.	Max.	Unit
P_{OUT}	$V_{\text{DD}} = 100\text{ V}$, $I_{\text{DQ}} = 2 \times 250\text{ mA}$, $P_{\text{IN}} = 2\text{ W}$, $f = 123\text{ MHz}$	450	580		W
h_{D}	$V_{\text{DD}} = 100\text{ V}$, $I_{\text{DQ}} = 2 \times 250\text{ mA}$, $P_{\text{IN}} = 2\text{ W}$, $f = 123\text{ MHz}$		70		%

Table 6. Pulse / 1 mec - 10 %

Symbol	Test conditions	Min.	Typ.	Max.	Unit
P_{OUT}	$V_{\text{DD}} = 100\text{ V}$, $I_{\text{DQ}} = 2 \times 250\text{ mA}$, $P_{\text{IN}} = 8\text{ W}$, $f = 123\text{ MHz}$		900		W
h_{D}	$V_{\text{DD}} = 100\text{ V}$, $I_{\text{DQ}} = 2 \times 250\text{ mA}$, $P_{\text{IN}} = 8\text{ W}$, $f = 123\text{ MHz}$		65		%

3 Impedance

Figure 2. Current conventions

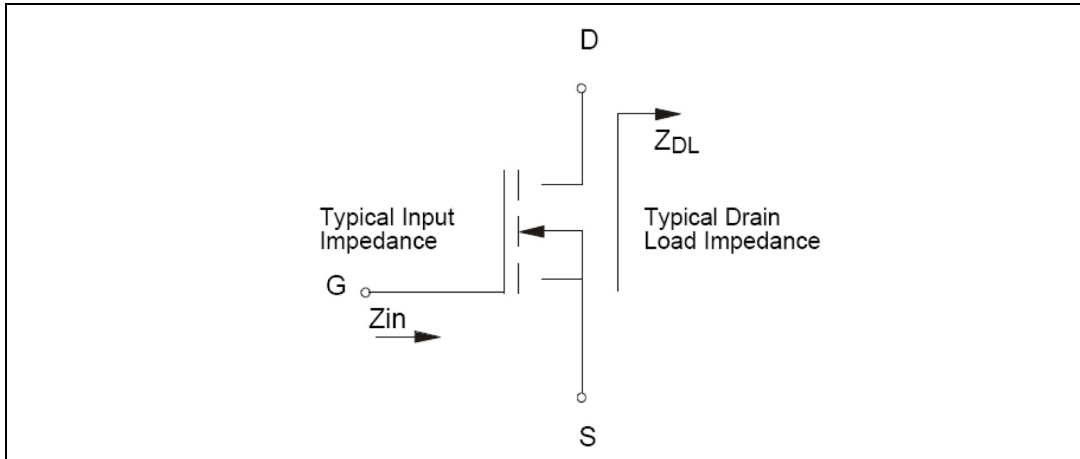

Table 7. Impedance data

Freq. (MHz)	Z _{IN} (Ω)	Z _{DL} (Ω)
123 MHz (Pulse)	1.0 - j 4.80	6.3 + j 10.5
123 MHz (CW)	0.8 - j 3.45	5.0 + j 13.0
64 MHz	1.4 - j 10.0	12.8 + j 14.0

Note: Measured gate to gate and drain to drain, respectively.

4 Electrical schematic and BOM

Figure 3. Electrical schematic

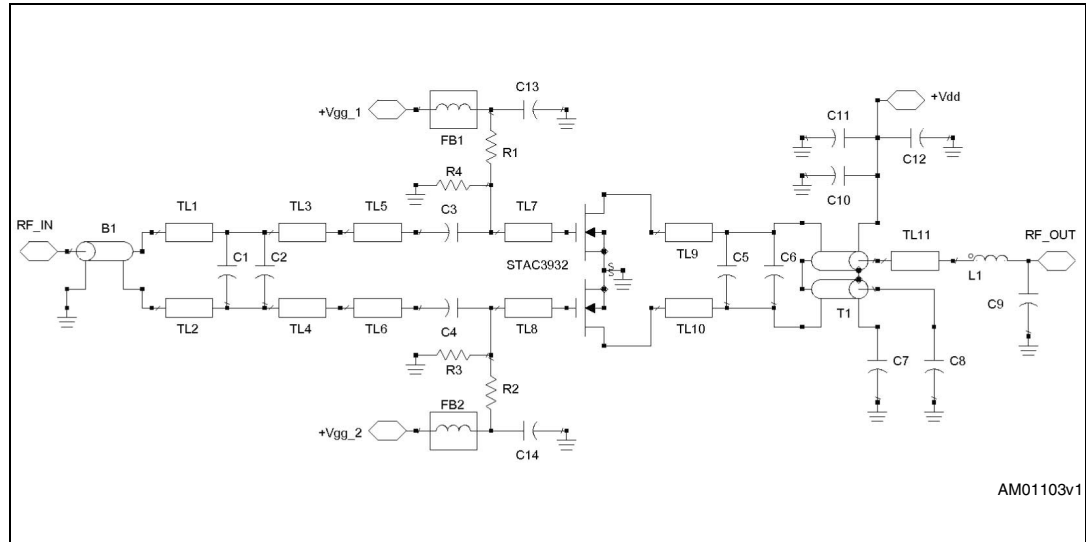

Table 8. Bill of materials

Component	Description
C1	270 pF ATC 100B chip capacitor
C2	180 pF ATC 100B chip capacitor
C3, C4	750 pF ATC 700B chip capacitor
C5, C8	43 pF ATC 100B chip capacitor
C6	20 pF ATC 100B chip capacitor
C7	1000 pF ATC 100C chip capacitor
C9	5.6 pF ATC 100B chip capacitor
C10	2200 pF ATC 100C chip capacitor
C11	470 pF ATC 100B chip capacitor
C12	100 μF, 200 V electrolytic capacitor
C13, C14	1200 pF ATC 700B chip capacitor
R1, R2	15 Ω 1/4 Watt chip resistor
R3, R4	30 Ω 1/4 watt axial lead resistor
L1	3 turns, 16 ga magnet wire, Id 3/8", .165" turn spacing, 78 nH
FB1, FB2	ferrite bead, Fair-Rite # 2743019447
B1	1/4λ balun transformer, RG316-25Ω ,16.5"
T1	20 ga teflon coated wire thru 4 copper tubes OD 1/8"x 1.5"

Table 8. Bill of materials (continued)

Component	Description
TL1, TL2	.740" x .200" microstrip
TL3, TL4	.360" x .200" microstrip
TL5, TL6	.480" x .350" microstrip
TL7, TL8	.220" x .350" microstrip
TL9, TL10	.350" x .660" microstrip
TL11	.415" x .200" microstrip
Board	.062" FR-4

5 Circuit layout

Figure 4. Circuit layout

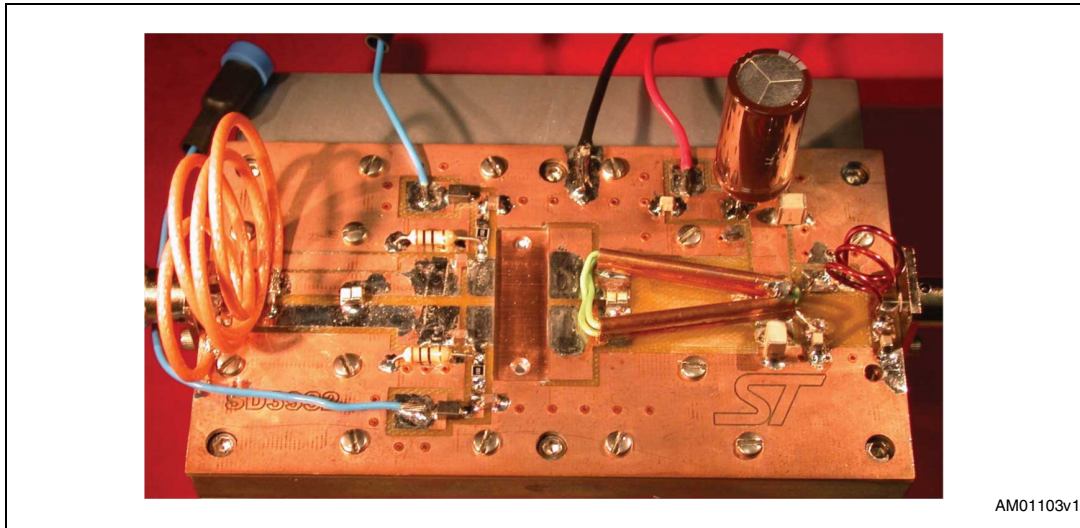

AM01103v1

Figure 5. Circuit layout

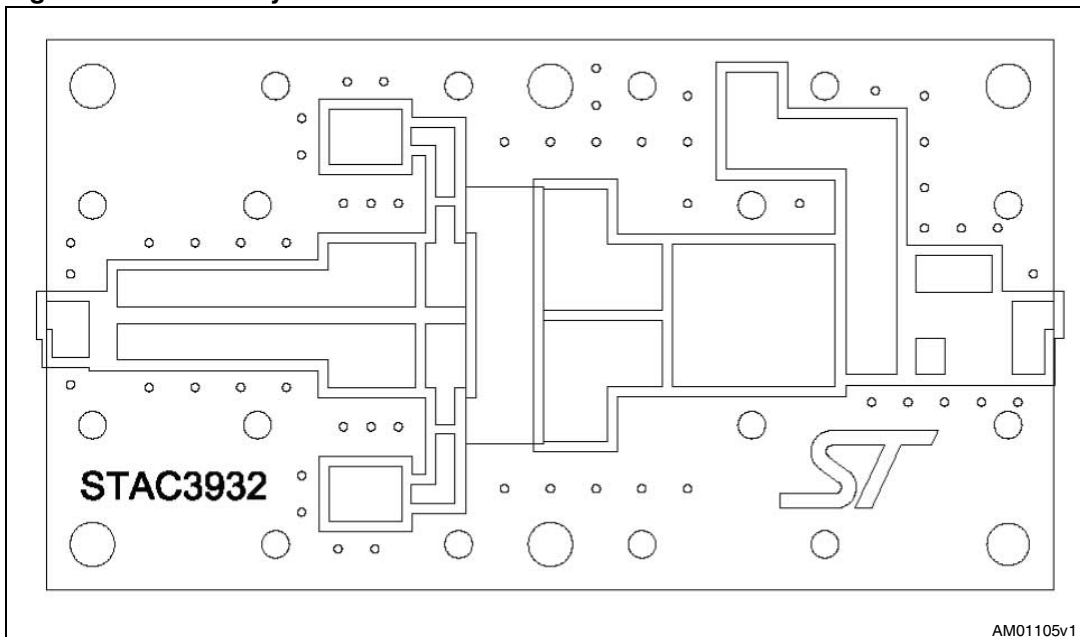

AM01105v1

6 Typical performance

Figure 6. Capacitances vs drain supply voltage

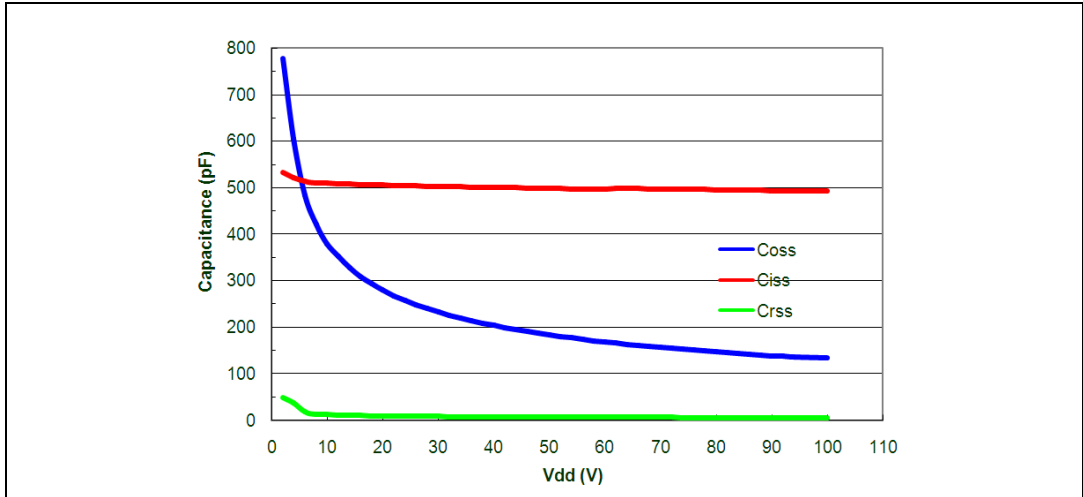
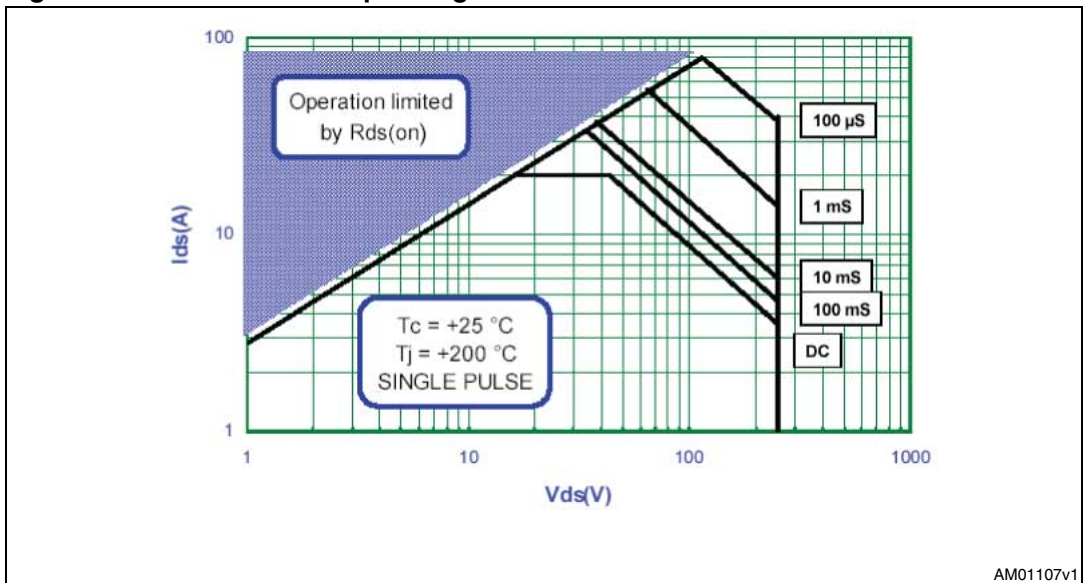
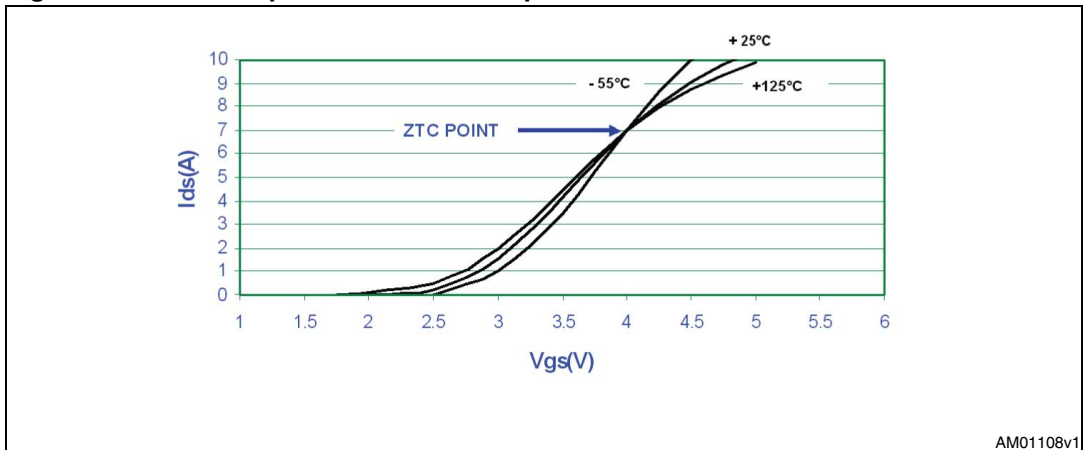

Figure 7. Maximum safe operating area



AM01107v1

Figure 8. Zero temperature coefficient point



AM01108v1

Figure 9. Output power and efficiency vs input power (CW)

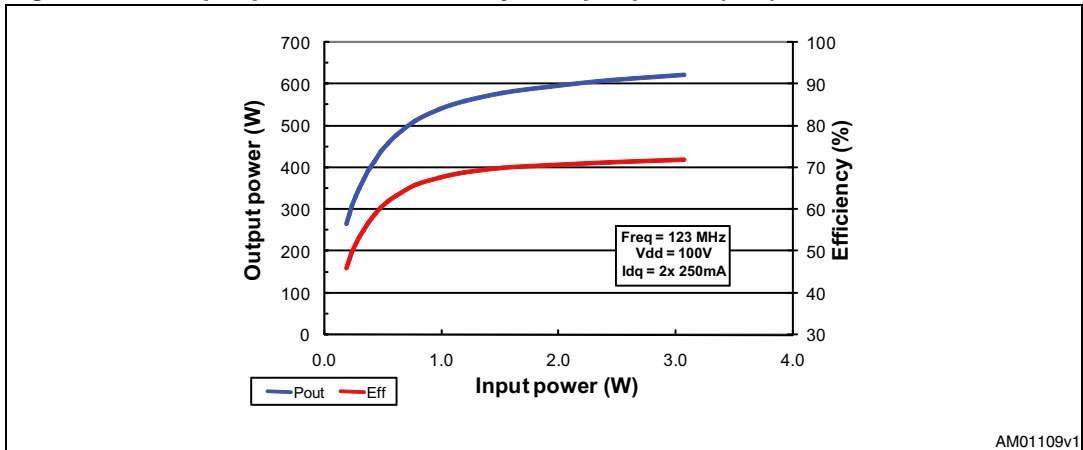

AM01109v1

Figure 10. Gain vs output power (CW)

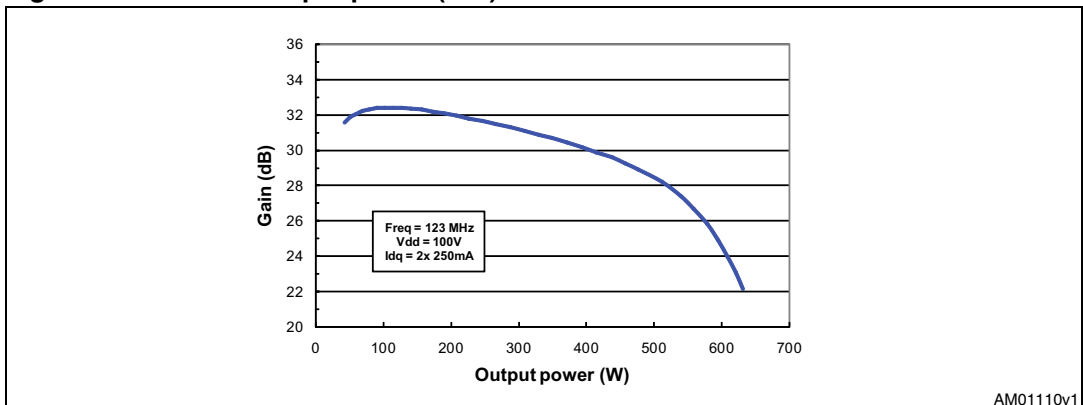

AM01110v1

Figure 11. Output power and efficiency vs input power (1 msec - 10%)

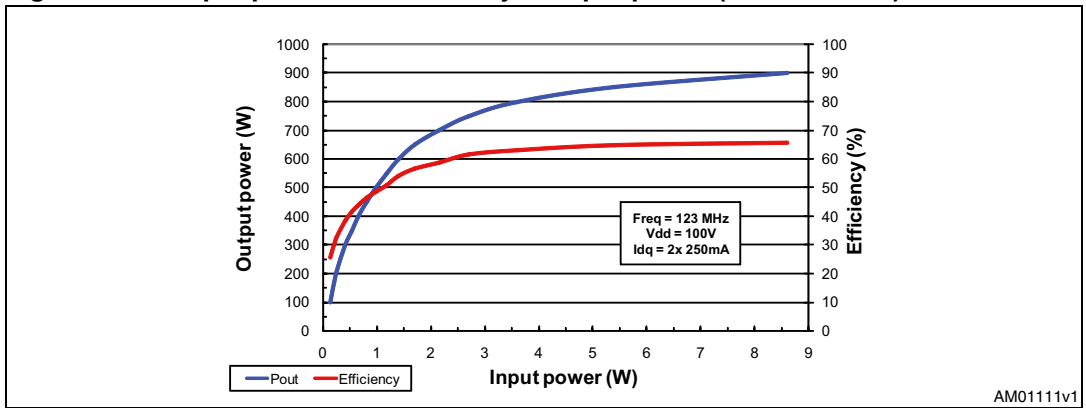

AM01111v1

7 Package mechanical data

In order to meet environmental requirements, ST offers these devices in different grades of ECOPACK® packages, depending on their level of environmental compliance. ECOPACK® specifications, grade definitions and product status are available at: www.st.com. ECOPACK is an ST trademark.

Table 9. STAC244B package dimensions

Dim.	mm.			Inch		
	Min	Typ	Max	Min	Typ	Max
A		5.33			0.210	
B		4.83			0.190	
C1		3.25			0.128	
C2		7.24			0.285	
C3		6.22			0.245	
D		9.78			0.385	
E		19.43			0.765	
F1		9.91			0.390	
F2		4.57			0.180	
F3		15.24			0.600	
G1		27.94			1.100	
G2		25.10			0.988	
G3		28.75			1.132	
G4		5.08			0.200	
H1		34.04			1.340	
H2		20.96			0.825	
I		0.15			0.006	
J		1.02			0.040	
K		1.57			0.062	
L1		5.21			0.205	
L2		5.33			0.210	
L3		3.25			0.128	
M		9.14			0.360	
N		17.91			0.705	
Controlling dimension: inches						

Figure 12. Package dimensions

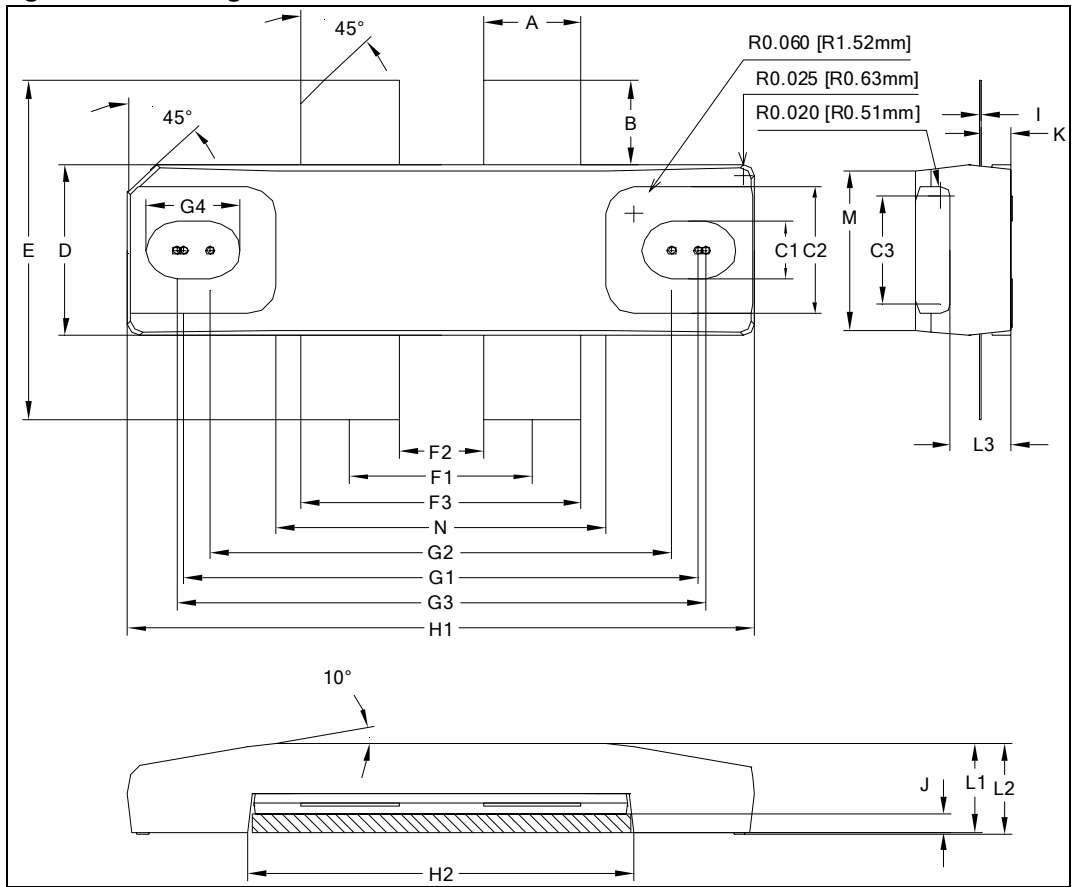

8 Revision history

Table 10. Document revision history

Date	Revision	Changes
06-Mar-2009	1	First release

Please Read Carefully:

Information in this document is provided solely in connection with ST products. STMicroelectronics NV and its subsidiaries ("ST") reserve the right to make changes, corrections, modifications or improvements, to this document, and the products and services described herein at any time, without notice.

All ST products are sold pursuant to ST's terms and conditions of sale.

Purchasers are solely responsible for the choice, selection and use of the ST products and services described herein, and ST assumes no liability whatsoever relating to the choice, selection or use of the ST products and services described herein.

No license, express or implied, by estoppel or otherwise, to any intellectual property rights is granted under this document. If any part of this document refers to any third party products or services it shall not be deemed a license grant by ST for the use of such third party products or services, or any intellectual property contained therein or considered as a warranty covering the use in any manner whatsoever of such third party products or services or any intellectual property contained therein.

UNLESS OTHERWISE SET FORTH IN ST'S TERMS AND CONDITIONS OF SALE ST DISCLAIMS ANY EXPRESS OR IMPLIED WARRANTY WITH RESPECT TO THE USE AND/OR SALE OF ST PRODUCTS INCLUDING WITHOUT LIMITATION IMPLIED WARRANTIES OF MERCHANTABILITY, FITNESS FOR A PARTICULAR PURPOSE (AND THEIR EQUIVALENTS UNDER THE LAWS OF ANY JURISDICTION), OR INFRINGEMENT OF ANY PATENT, COPYRIGHT OR OTHER INTELLECTUAL PROPERTY RIGHT.

UNLESS EXPRESSLY APPROVED IN WRITING BY AN AUTHORIZED ST REPRESENTATIVE, ST PRODUCTS ARE NOT RECOMMENDED, AUTHORIZED OR WARRANTED FOR USE IN MILITARY, AIR CRAFT, SPACE, LIFE SAVING, OR LIFE SUSTAINING APPLICATIONS, NOR IN PRODUCTS OR SYSTEMS WHERE FAILURE OR MALFUNCTION MAY RESULT IN PERSONAL INJURY, DEATH, OR SEVERE PROPERTY OR ENVIRONMENTAL DAMAGE. ST PRODUCTS WHICH ARE NOT SPECIFIED AS "AUTOMOTIVE GRADE" MAY ONLY BE USED IN AUTOMOTIVE APPLICATIONS AT USER'S OWN RISK.

Resale of ST products with provisions different from the statements and/or technical features set forth in this document shall immediately void any warranty granted by ST for the ST product or service described herein and shall not create or extend in any manner whatsoever, any liability of ST.

ST and the ST logo are trademarks or registered trademarks of ST in various countries.

Information in this document supersedes and replaces all information previously supplied.

The ST logo is a registered trademark of STMicroelectronics. All other names are the property of their respective owners.

© 2009 STMicroelectronics - All rights reserved

STMicroelectronics group of companies

Australia - Belgium - Brazil - Canada - China - Czech Republic - Finland - France - Germany - Hong Kong - India - Israel - Italy - Japan - Malaysia - Malta - Morocco - Singapore - Spain - Sweden - Switzerland - United Kingdom - United States of America

www.st.com

