



TETRA ANTENNAS

from **JAYBEAM**



- Jaybeam have been involved with TETRA & TETRAPOL systems since their inception.
- Close co-operation with the major OEMs and system operators have resulted in a first class product range, offering real solutions to the most demanding applications.
- Full technical back up is offered with all of our range, a feature much appreciated by all customers.
- Our long experience in both Cellular and PMR radio enables us to produce the most suitable products for all frequency ranges that TETRA uses.

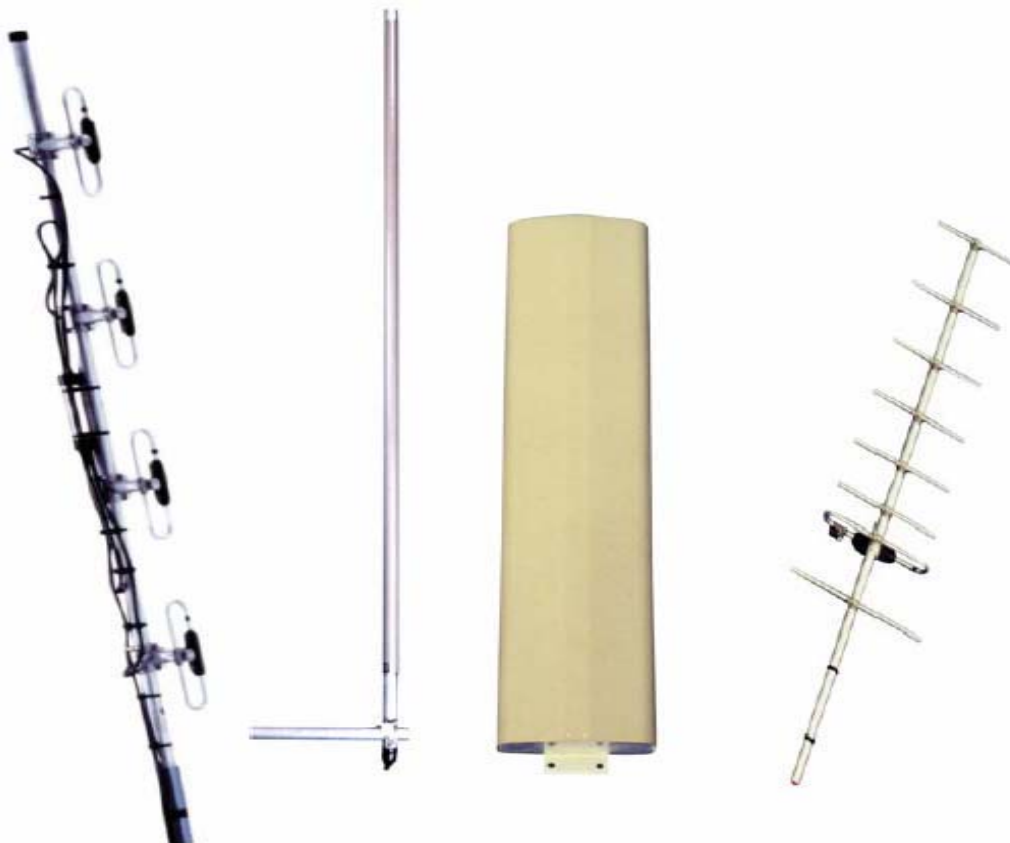

Recent Projects:

- 'Airwave' system for UK police services (currently the largest project in the world)
- UK - London Underground (Motorola)
- 'Astrid' project in Belgium (with Nokia)
- UK: Inquam-Dolphin project
- Ireland: 'Barracuda for NI Police, (with Motorola) + pilot scheme for Garda (Nokia)
- Many others in countries, France, Saudi Arabia, Austria, Slovenia, Croatia, Singapore, Czech Rep. Hungary, Iceland etc.

Omnis - Colinears



Our range of Colinear antennas is well established and are proving a favourite choice among operators. Lightning proof capability, electrical beam tilt and high power handling are some of the main features. Standard/preferred models are listed here.

Type No.	Gain dBi	V. B/W
7530 500	5.0	36°
7586 380	8.15	16°
7586 386 (6° tilt)	7.2	17°
7586 388 (8° tilt)	7.2	17°
7586 392 (12° tilt)	7.2	20°
7549 200 (0° tilt)	10.0	7.5°
7549 206 (6° tilt)	10.0	8.0°

Lightweight Colinears

7501 380	2.1	80°
7533 395	5.0	35°
7536 395	7.0	17°

'2 in 1' Antennas

5201000	2x5.0	2x36°
7548380	2x7.0	2x20°
7548386 (6° tilt)	2x7.0	2x20°

4Stacks, Yagis



The ubiquitous 4 stack dipole has been around for many years now and has been upgraded to give the better intermodulation performance that is necessary for modern digital systems.

A good range of yagi antennas is made for repeater sites and fixed mobile situations.

Type No.	Gain dBi	H. B/W	V. B/W
7047 200	7.3	360°	20°
7148 200	11.0	160°	17°
7148 205 (5° tilt)	11.0	160°	17°
7148 210 (10° tilt)	11.0	160°	17°

Yagi antennas for repeaters, fixed mobiles etc.

Type No.	Gain dBi	'H'. B/W	'E'. B/W
7014 385 (12 ele)	14.2	36°	40°
7043 385 (8 ele)	12.2	54°	45°
7042 385 (6 ele)	10.6	56°	46°
7041 385 (4 ele)	9.6	78°	58°
7040 385 (3 ele)	7.2	120°	70°
7039 385 (2 ele)	5.2	150°	75°

Sector types



Crossed polarisation panels are the most used types for sector coverage, often deployed in urban areas.

Electrical beam tilt is available.

Our type 5004 is a sector type with adjustable horizontal beamwidth.

Type No.	Gain dBi	H. B/W	V. B/W
5043 000	2x14.0	80°	19°
5043 110 (10° tilt)	2x14.0	80°	19°
5043 015 (15° tilt)	2x13.5	80°	20°
5023 010 (10° tilt)	2x11.2	80°	28°
5023 015 (15° tilt)	2x11.2	80°	28°
5049 400	1x14.0	92°	19°

Adjustable Corner reflectors

5004 380	11.45 at 90° setting 10.55 at 120° 9.55 at 140° 8.45 at 180°	19°
5004 390	is as above, but with 10° tilt.	

Microcell & Indoor

5047 000	Wall mounted directional
MA521 P00	Ceiling mounted omni

Full data sheets of all types shown and others in our range are available in our CDROM.

ASCII radiation pattern files are also on the CDROM

In addition to our TETRA range, Jaybeam, in conjunction with our sister company, MAT Equipement S.A., offer antenna solutions for most wireless systems from MF-HF through VHF -UHF -SHF up to 5.9GHz.

Base station antennas for today's mobile systems from CDMA-AMPS through GSM 900-1800 and UMTS/3G are a major part of our business. We are in the forefront of latest developments in this field and continue to produce a comprehensive range of excellent products.

Other active fields include, PMR - Trunked Radio - Telemetry - Paging - Ground to Air - Marine - VHF Broadcasting - DAB - Railways - WLL and RLAN.

Mounting hardware and accessories are offered for all our antenna ranges



Jaybeam Ltd
Rutherford Drive, Park Farm South, Wellingborough,
Northants, England NN8 6AX
Tel: +44(0) 1933 408408
Fax: +44(0) 1933 408404
Email: sales@jaybeam.co.uk
www.jaybeam.co.uk



MAT Equipement S.A.
ZI La Boitardiere, Chemin du Roy,
37400 Amboise, France
Tel: +33(0)2 47 30 69 70
Fax: +33(0)2 47 57 35 06
www.matjaybeam.com



Typical Radiation Pattern (E Plane)

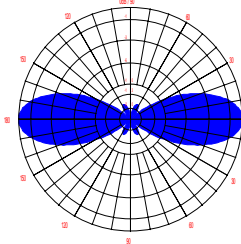

Typical Radiation Pattern (H Plane)

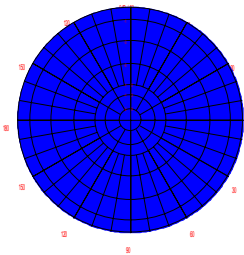

Type Number: 7530 500

A high quality , robust antenna that offers **lightning protection**. Related to our well known and highly regarded 7586 series, it is a 3dB gain version giving a more compact size and lower imposed loadings on mounting structures. Particular attention has been given to keeping intermodulation products to the minimum possible.

Electrical Characteristics	7530 500
Frequency	380 – 400 MHz
Gain (max)	5.0 dBi
Power	300 W CW
VSWR	< 1.5:1 typical
Polarisation	Linear , vertical
Horizontal Beamwidth	36°
Elevation Beamwidth	36° , -3 dB point
Electrical Downtilt	optional, 5 or 10deg
Lightning Protection	Will withstand pulse of 2.5×10^6 A ² s. All metal parts DC grounded
Impedance	50Ω
3 rd Order Intermodulation	< - 153dBc with 2 x 20 watt carriers
RF Termination	7/16DIN female located in the antenna base.

Mechanical Characteristics	
Material	GRP shroud Colour Pale Grey RAL 7035 Aluminium mounting section and cap
Dimensions	1905 x 52Ø mm
Weight	4.5 kg
Wind Surface area	0.10m ²
Survival Windspeed	In excess of 250km/hour
Wind Loading	130 N maximum @ 160 km/hour

General Antenna Information

Normal mounting.

ASCII format radiation patterns are available upon request.

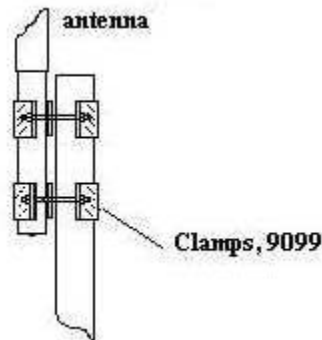

(Various other clamps are available)

MAT JAYBEAM reserve the right to modify or amend any antenna or specification without prior notice

**Type 7586 TETRA
Base Station Antenna
Omnidirectional Colinear
Lightning Proof, 0° Beam Tilt option.**

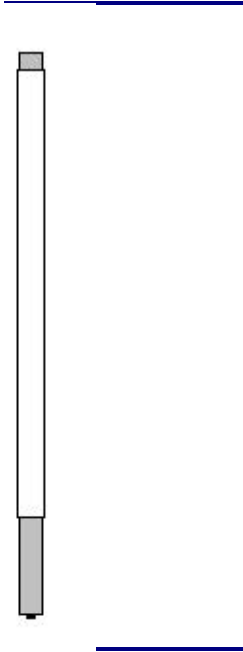

Typical Radiation Pattern (E Plane)

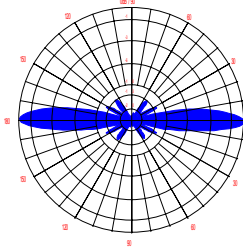

Typical Radiation Pattern (H Plane)

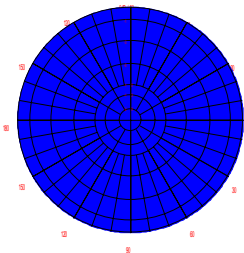

Type Number: 7586 380 - 7586 390

A high quality, robust antenna that offers **lightning protection**. It offers wide bandwidths and due to its centre-fed dipole construction, carefully controlled radiation patterns, with the **option of beamtilt**. Lightning proof design makes this antenna particularly suitable for exposed sites. The high efficiency and generous power rating of the **7586** can offer many solutions for modern trunked systems such as **TETRA**.

Electrical Characteristics	7586 380	7586 390
RF Termination	7/16 female located in the antenna base.	'N' female located in the antenna base.
Frequency	380 – 400 MHz	
Gain (max)	8.15 dBi	
Power	300 W CW	
VSWR	< 1.5:1 typical	
Polarisation	Linear, vertical	
Horizontal Beamwidth	360°	
Elevation Beamwidth	16°, -3 dB point	
Intermodulation figures	< -153 dBc for 2 x 20watt carriers	
Electrical Downtilt	0°	
Lightning Protection	Will withstand pulse of 2.5 x 10 ⁶ A ² s. All metal parts DC grounded	
Impedance	50Ω	

Mechanical Characteristics	
Material	GRP shroud Colour Pale Grey RAL 7035 Aluminium mounting section and cap
Dimensions	3100 x 52Ø mm
Weight	7.0 kg
Wind Surface area	0.14m ²
Survival windspeed	In excess of 250km/hour
Wind Loading	175 N maximum @ 160 km/hour
	Rv0303

General Antenna Information
Normal mounting. ASCII format radiation patterns are available upon request.

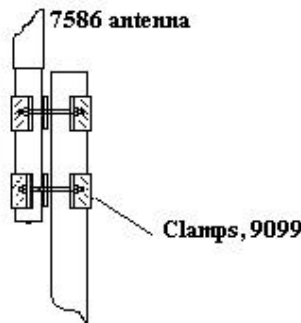

MAT JAYBEAM reserve the right to modify or amend any antenna or specification without prior notice

**Type 7586 TETRA
Base Station Antenna
Omnidirectional Colinear
Lightning Proof, 6° Beam Tilt option.**

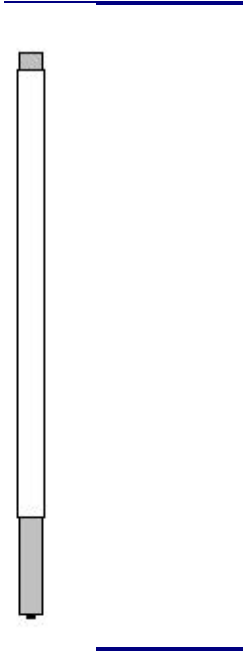

Typical Radiation Pattern (E Plane)

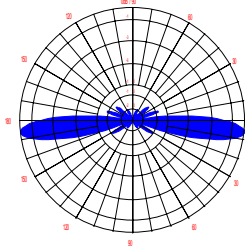

Typical Radiation Pattern (H Plane)

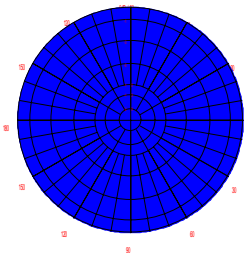

Type Number: 7586 386 – 7586 396

A high quality, robust antenna that offers **lightning protection**. It offers wide bandwidths and due to its centre-fed dipole construction, carefully controlled radiation patterns, with the **option of beamtilt**. Lightning proof design makes this antenna particularly suitable for exposed sites. The high efficiency and generous power rating of the **7586** can offer many solutions for modern trunked systems such as **TETRA**.

Electrical Characteristics	7586 386	7586 396
RF Termination	7/16 female located in the antenna base.	'N' female located in the antenna base
Frequency	380 – 400 MHz	
Gain (max)	7.2 dBi	
Power	300 W CW	
VSWR	< 1.5:1 typical	
Polarisation	Linear, vertical	
Horizontal Beamwidth	360°	
Elevation Beamwidth	17°, -3 dB point	
Electrical Downtilt	6°	
Intermodulation figures	< -153 dBc for 2 x 20watt carriers	
Lightning Protection	Will withstand pulse of 2.5 x 10 ⁶ A ² s. All metal parts DC grounded	
Impedance	50Ω	

Mechanical Characteristics	
Material	GRP shroud Colour Pale Grey RAL 7035 Aluminium mounting section and cap
Dimensions	3100 x 52Ø mm
Weight	7.0 kg
Wind Surface area	0.14m ²
Survival Windspeed	In excess of 250km/hour
Wind Loading	175 N maximum @ 160 km/hour Rv0303

General Antenna Information

Normal mounting.

ASCII format radiation patterns are available upon request.

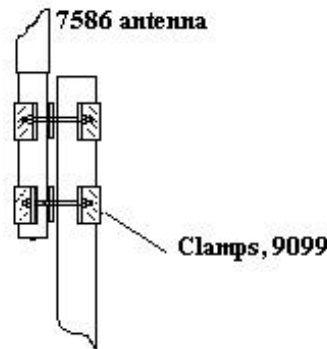

MAT JAYBEAM reserve the right to modify or amend any antenna or specification without prior notice

**Type 7586 TETRA
Base Station Antenna
Omnidirectional Colinear
Lightning Proof, 8° Beam Tilt option.**

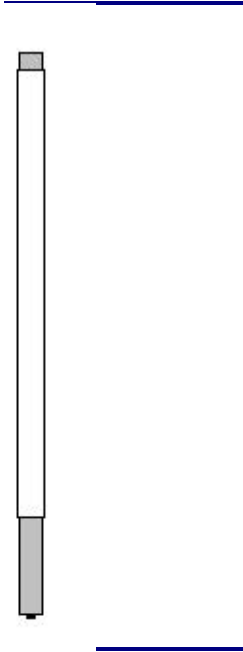

Typical Radiation Pattern (E Plane)

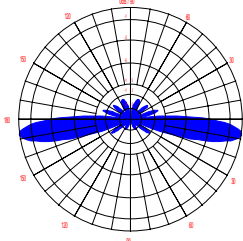

Typical Radiation Pattern (H Plane)

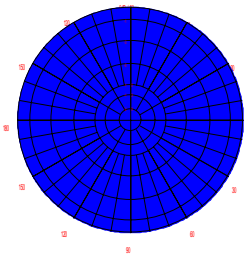

Type Number: 7586 388 – 7586 398

A high quality , robust antenna that offers **lightning protection**. It offers wide bandwidths and due to its centre-fed dipole construction, carefully controlled radiation patterns, with the **option of beamtilt**. Lightning proof design makes this antenna particularly suitable for exposed sites. The high efficiency and generous power rating of the **7586** can offer many solutions for modern trunked systems such as **TETRA**.

Electrical Characteristics	7586 388	7586 398
RF Termination	7/16 female located in the antenna base.	'N' female located in the antenna base
Frequency	380 – 400 MHz	
Gain (max)	7.2 dBi	
Power	300 W CW	
VSWR	< 1.5:1 typical	
Polarisation	Linear , vertical	
Horizontal Beamwidth	360°	
Elevation Beamwidth	17° , -3 dB point	
Electrical Downtilt	8°	
Intermodulation figures	< -153dBc for 2 x 20 watt carriers	
Lightning Protection	Will withstand pulse of 2.5 x 10 ⁶ A ² s. All metal parts DC grounded	
Impedance	50Ω	

Mechanical Characteristics	
Material	GRP shroud Colour Pale Grey RAL 7035 Aluminium mounting section and cap
Dimensions	3100 x 52Ø mm
Weight	7.0 kg
Wind Surface area	0.14m ²
Survival Windspeed	In excess of 250km/hour
Wind Loading	175 N maximum @ 160 km/hour Rv0303

General Antenna Information

Normal mounting.

ASCII format radiation patterns are available upon request.

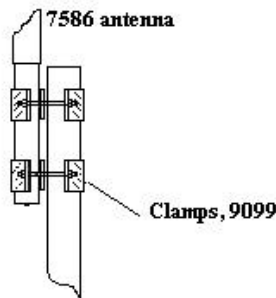

MAT JAYBEAM reserve the right to modify or amend any antenna or specification without prior notice

**Type 7586 TETRA
Base Station Antenna
Omnidirectional Colinear
Lightning Proof, 12° Beam Tilt option.**

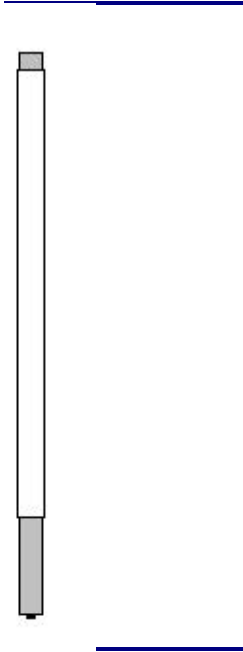

Typical Radiation Pattern (E Plane)

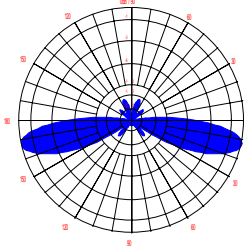

Typical Radiation Pattern (H Plane)

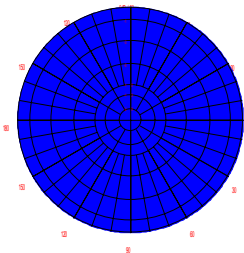

Type Number: 7586 392 – 7586 382

A high quality, robust antenna that offers **lightning protection**. It offers wide bandwidths and due to its centre-fed dipole construction, carefully controlled radiation patterns, with the **option of beamtilt**. Lightning proof design makes this antenna particularly suitable for exposed sites. The high efficiency and generous power rating of the **7586** can offer many solutions for modern trunked systems such as **TETRA**.

Electrical Characteristics	7586 392	7586 382
RF Termination	7/16 female located in the antenna base.	'N' female located in the antenna base.
Frequency	380 – 400 MHz	
Gain (max)	7.2 dBi	
Power	300 W CW	
VSWR	< 1.5:1 typical	
Polarisation	Linear, vertical	
Horizontal Beamwidth	360°	
Elevation Beamwidth	20°, -3 dB point	
Electrical Downtilt	12°	
Intermodulation figures	< -153dBc for 2 x 20watt carriers	
Lightning Protection	Will withstand pulse of 2.5 x 10 ⁶ A ² s. All metal parts DC grounded	
Impedance	50Ω	

Mechanical Characteristics	
Material	GRP shroud Colour Pale Grey RAL 7035 Aluminium mounting section and cap
Dimensions	3100 x 52Ø mm
Weight	7.0 kg
Wind Surface area	0.14m ²
Survival Windspeed	In excess of 250km/hour
Wind Loading	175 N maximum @ 160 km/hour Rv0303

General Antenna Information

Normal mounting.

ASCII format radiation patterns are available upon request.

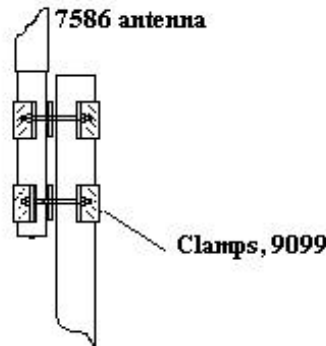

MAT JAYBEAM reserve the right to modify or amend any antenna or specification without prior notice

**Type 7549 TETRA
Base Station Antenna
Omnidirectional Colinear, High Gain
Lightning Proof, Beam Tilt option.**



Typical Radiation Pattern (E Plane)

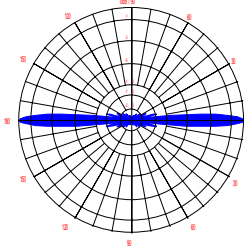

Typical Radiation Pattern (H Plane)

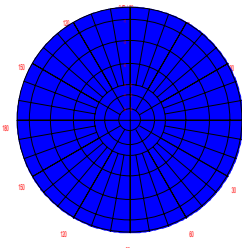

Type Number: 7549 200

A high quality , robust and **unobtrusive** antenna that offers **lightning protection**.
It offers wide bandwidths and due to its centre-fed dipole construction, carefully controlled radiation patterns, with the **option of beamtilt**.
Lightning proof design makes this antenna particularly suitable for exposed sites. The high efficiency and generous power rating of the **7549** can offer many solutions for modern trunked systems such as **TETRA**.

Electrical Characteristics	7549 200
Frequency	380-400 MHz
Gain (max)	10.0 dBi
Power	300 W CW
VSWR	< 1.5:1 typical
Polarisation	Linear , vertical
Horizontal Beamwidth	360°
Elevation Beamwidth	7.5° , -3 dB point
Electrical Downtilt	0°
Lightning Protection	Will withstand pulse of 2.5 x 10 ⁶ A ² s. All metal parts DC grounded, metal cap
3 rd order Intermodulation	- 148dBc for 2 x 20 watt carriers
Impedance	50Ω
RF Termination	N female or 7/16 DIN female on download

Mechanical Characteristics	
Material	GRP shroud Colour Pale Grey RAL 7035 Aluminium mounting section (70mmØ)
Dimensions	5400 x 57Ø mm
Weight	12.0 kg
Max operational wind speed	260 km/hr
Wind Loading	380 N maximum @ 160 km/hour

Rv0403

**General Antenna Information
Normal mounting.**

ASCII format radiation patterns are available upon request.

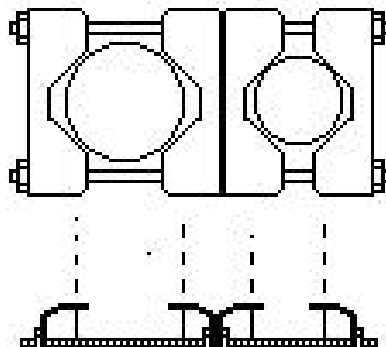

Clamps to fit pipes of 115mmØ



MAT JAYBEAM reserve the right to modify or amend any antenna or specification without prior notice

**Type 7549 TETRA
Base Station Antenna
Omnidirectional Colinear, High Gain
Lightning Proof, 6° Beam Tilt**



Type Number: 7549 206

A high quality , robust and **unobtrusive** antenna that offers **lightning protection**.

It offers wide bandwidths and due to its centre-fed dipole construction, carefully controlled radiation patterns, with the **option of beamtilt**. Lightning proof design makes this antenna particularly suitable for exposed sites. The high efficiency and generous power rating of the **7549** can offer many solutions for modern trunked systems such as **TETRA**.

Electrical Characteristics	7549 206
Frequency	380 – 400 MHz
Gain (max)	11.0 dBi
Power	300 W CW
VSWR	< 1.5:1 typical
Polarisation	Linear , vertical
Horizontal Beamwidth	360°
Elevation Beamwidth	7.5° , -3 dB point
Electrical Downtilt	6°
Lightning Protection	Will withstand pulse of $2.5 \times 10^6 \text{ A}^2\text{s}$. All metal parts DC grounded
3 rd Order Intermodulation	-148dBc for 2 x 20 watt carriers
Impedance	50Ω
RF Termination	7/16 female

Typical Radiation Pattern (E Plane)

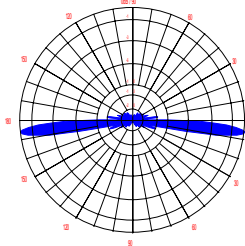

Typical Radiation Pattern (H Plane)

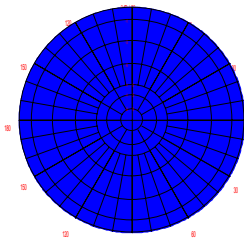

Mechanical Characteristics	
Material	GRP shroud Colour Pale Grey RAL 7035 Aluminium mounting section and cap
Dimensions	5400 x 60Ø mm
Weight	12.0 kg
Wind Surface area	0.3m ²
Wind Loading	380 N maximum @ 160 km/hour Rv0403

General Antenna Information
Normal mounting.

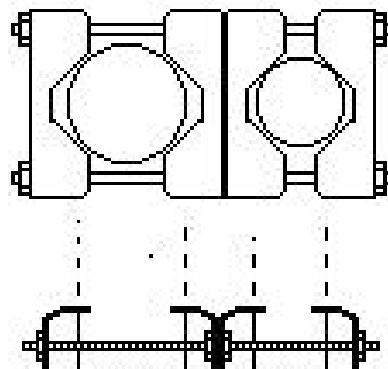

ASCII format radiation patterns are available upon request.

Clamps to fit pipes of 115mmØ



MAT JAYBEAM reserve the right to modify or amend any antenna or specification without prior notice

Type 7501
Base Station / Fixed Mobile Antenna
Omnidirectional Dipole

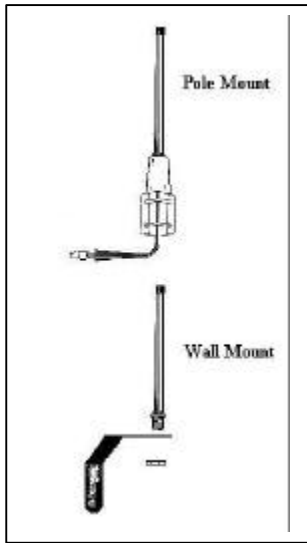

Type Number: 7501

One of our most popular antennas, the 7501 finds applications in many areas.

Highly efficient, it is ideal for low power applications as well as everyday PMR and TETRA situations

It offers wide bandwidths and due to its centre-fed dipole construction, carefully controlled radiation pattern

Electrical Characteristics		7501 ***
Frequency	7501 380	380 – 430 MHz
	7501 450	420-470,MHz
	7501 470	450-500 MHz
Gain (max)	2.15 dBi	
Power	150 W CW	
VSWR	< 1.5:1 typical	
Polarisation	Linear , vertical	
Horizontal Beamwidth	360°	
Elevation Beamwidth	80° , -3 dB point	
Lightning Protection	All metal parts DC grounded	
Impedance	50Ω	
RF Termination	N female fitted to 0.3m RG213 Coaxial Cable Downlead. (7/16 DIN Optional).	

All antennas are DC Grounded

Typical Radiation Pattern (E Plane)

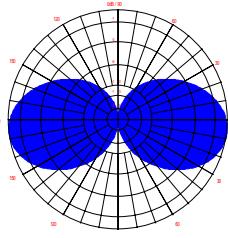

Typical Radiation Pattern (H Plane)

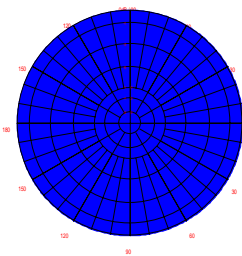

Mechanical Characteristics	
Material	GRP shroud Colour White Alochromed Aluminium mounting section with Stainless Steel Fixings
Dimensions	605mm x 21Ø mm
Weight	0.9 kg
Wind Surface area	0.012m ²
Wind Loading	16 N maximum @ 160 km/hour

General Antenna Information

Mounting: Integral mounting clamp allows fixing to 50mm diameter pipes or horizontal rail.

Can be supplied with wall mounting to special order.

ASCII format radiation patterns are available upon request.



MAT JAYBEAM reserve the right to modify or amend any antenna or specification without prior notice



Type Number: 7533

This antenna is long established and carries R.A. type approval for UHF telemetry systems (MPT 1411). It is also finding favour with TETRA operators.

Highly efficient, it is easily mounted using the integrated clamp, onto vertical poles or horizontal rails.

It offers wide bandwidths and due to its centre-fed dipole construction, carefully controlled radiation pattern

Electrical Characteristics	7533 ***
Frequency Versions	380-410, 400-440 420-450, 430-470, 490-510 MHz
Gain (max)	3.0 dBd
Power	150 W CW
VSWR	< 1.5:1 typical
Polarisation	Linear , vertical
Horizontal Beamwidth	360°
Elevation Beamwidth	35° , -3 dB point
Lightning Protection	All metal parts DC grounded
Impedance	50Ω
RF Termination	N female fitted to 0.3m RG213 Coaxial Cable Downlead. (7/16 DIN Optional).

Typical Radiation Pattern (E Plane)

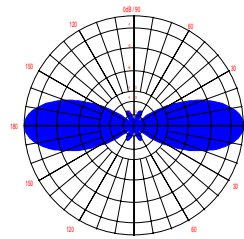

Typical Radiation Pattern (H Plane)

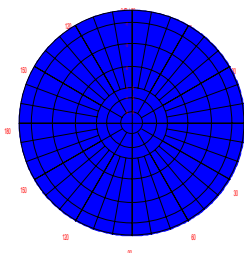

All antennas are DC Grounded

Mechanical Characteristics	
Material	GRP shroud Colour White Alochromed Aluminium mounting section with Stainless Steel Fixings
Length	1500mm
Weight	1.1 kg
Wind Surface area	0.0255m ²
Wind Loading	35 N maximum @ 160 km/hour

General Antenna Information

Mounting: Integral mounting clamp allows fixing to 50mm diameter pipes or horizontal rail.



ASCII format radiation patterns are available upon request.



MAT JAYBEAM reserve the right to modify or amend any antenna or specification without prior notice



Type Number: 7536

This antenna is long established and carries R.A. type approval for UHF telemetry systems (MPT 1411). It is also finding favour with TETRA operators.

Highly efficient, it is easily mounted using the integrated clamp, onto vertical poles or horizontal rails.

It offers wide bandwidths and due to its centre-fed dipole construction, carefully controlled radiation pattern

Electrical Characteristics	7536 ***
Frequency Versions	380-400, 400-430 420-450, 440-470 MHz
Gain (max)	5.5 dBd
Power	150 W CW
VSWR	< 1.5:1 typical
Polarisation	Linear , vertical
Horizontal Beamwidth	360°
Elevation Beamwidth	17° , -3 dB point
Lightning Protection	All metal parts DC grounded
Impedance	50Ω
RF Termination	N female fitted to 0.3m RG213 Coaxial Cable Downlead. (7/16 DIN Optional).

Typical Radiation Pattern (E Plane)

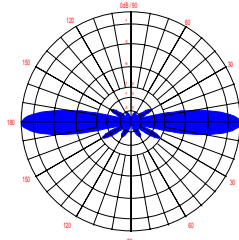

Typical Radiation Pattern (H Plane)

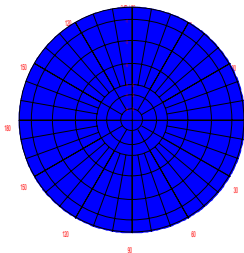

All antennas are DC Grounded

Mechanical Characteristics

Material	GRP shroud Colour White Alochromed Aluminium mounting section with Stainless Steel Fixings
Length	2700mm
Weight	1.8 kg
Wind Surface area	0.054m ²
Wind Loading	73 N maximum @ 160 km/hour

General Antenna Information

Mounting: Integral mounting clamp allows fixing to 50mm diameter pipes or horizontal rail.



ASCII format radiation patterns are available upon request.



MAT JAYBEAM reserve the right to modify or amend any antenna or specification without prior notice

**Type 5201 Two in One
TETRA Base Station Antenna
Omnidirectional Colinears, Medium Gain
Lightning Proof.**



Type Number: 5201 000

A high quality , robust and **unobtrusive** antenna that offers two separate omnidirectional colinear antennas in one slim housing.
Good isolation between the antennas allow for diversity.
Lightning proof design makes this antenna particularly suitable for exposed sites. The ascetic appearance can contribute to an unobtrusive site, often necessary in these environmentally sensitive times.

Electrical Characteristics	5201 000
Frequency	380-400 MHz
Gain Top	4.9dBi
Bottom	5.0dBi
Power	300 W each port
VSWR	< 1.4:1 typical
Polarisation	Linear , vertical
Horizontal Beamwidth	360°
Elevation Beamwidth	36° , -3 dB point
Isolation between ports	< 27 dB
Intermodulation (3 rd Order)	< -153dBc for 2 x 20watt carriers
Lightning Protection	Will withstand pulse of $2.5 \times 10^6 \text{ A}^2\text{s}$. All metal parts DC grounded
Impedance	50Ω
RF Termination	2x 7/16 DIN female on cable downloads

Typical Radiation Pattern (E Plane)

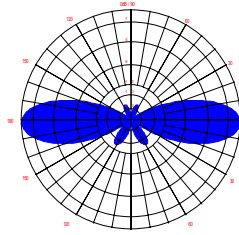

Typical Radiation Pattern (H Plane)

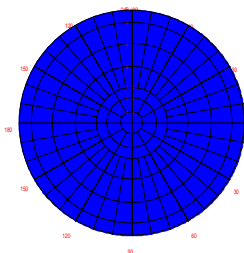

Mechanical Characteristics	
Material	GRP shroud Colour Pale Grey RAL 7035 Aluminium mounting section and cap
Dimensions	3160 x 52Ø mm
Weight	7.0 kg
Wind Loading	180 N maximum @ 160 km/hour

General Antenna Information
Normal mounting.

ASCII format radiation patterns are available upon request.

Clamps to fit pipes of 115mmØ are available.

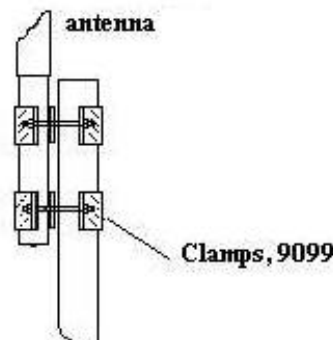

MAT JAYBEAM reserve the right to modify or amend any antenna or specification without prior notice

**Type 7548 Two in One
TETRA Base Station Antenna
Omnidirectional Colinear, Good Isolation.
Lightning Proof. High Gain. 0° tilt**

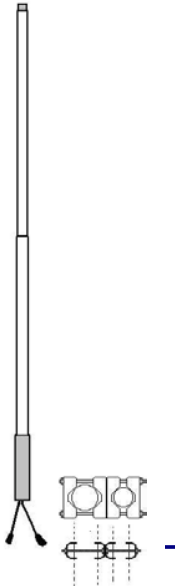

Typical Radiation Pattern (E Plane)

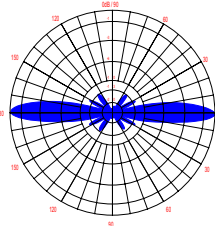

Typical Radiation Pattern (H Plane)

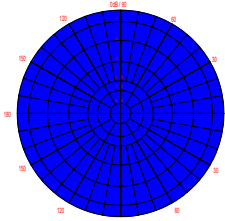

Type Number: 7548 380

A high quality, robust and **unobtrusive** antenna that offers two separate Hi-gain omnidirectional antennas in one slim housing. Good isolation between the antennas allow for diversity. Lightning proof design makes this antenna particularly suitable for exposed sites. The ascetic appearance can contribute to an unobtrusive base site, often necessary in these environmentally sensitive times.

Electrical Characteristics	7548 380
Frequency	380 – 400 MHz
Gain Top	6.4 dBi
Gain Bottom	7.3 dBi
Power	300 W CW (each port)
VSWR	< 1.4:1 maximum
Polarisation	Linear, vertical
Horizontal Beamwidth	360°
Elevation Beamwidth	20.5°, -3 dB point
Electrical Downtilt	0°
Isolation between antennas	< 37 dB
Lightning Protection	Will withstand pulse of 2.5×10^6 A ² s. All metal parts DC grounded
Impedance	50Ω
RF Termination	2 x 7/16 female on cable downloads

Mechanical Characteristics	
Material	GRP shroud Colour White Aluminium mounting section and cap
Dimensions	5780 x 60Ø mm
Weight	12.5 kg
Wind Surface area	0.30m ²
Wind Loading	430 N maximum @ 160 km/hour

General Antenna Information
Normal mounting.

ASCII format radiation patterns are available upon request.

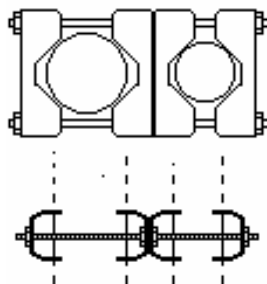

Clamps to fit pipes of 115mmØ

MAT JAYBEAM reserve the right to modify or amend any antenna or specification without prior notice

**Type 7548 Two in One
TETRA Base Station Antenna
Omnidirectional Colinear, Good Isolation.
Lightning Proof. High Gain. 6° tilt**



Type Number: 7548 386

A high quality, robust and **unobtrusive** antenna that offers two separate Hi-gain omnidirectional antennas in one slim housing. Good isolation between the antennas allow for diversity. Lightning proof design makes this antenna particularly suitable for exposed sites. The ascetic appearance can contribute to an unobtrusive base site, often necessary in these environmentally sensitive times.

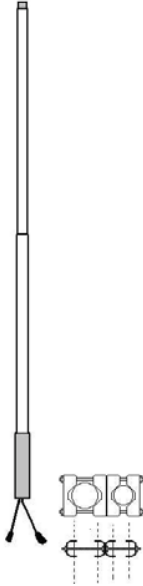

Typical Radiation Pattern (E Plane)

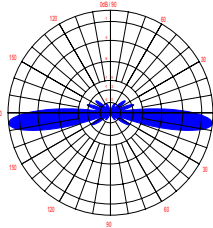

Typical Radiation Pattern (H Plane)

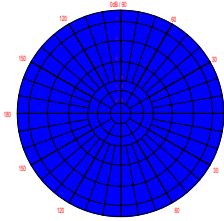

Electrical Characteristics	7548 386
Frequency	380 – 400 MHz
Gain Top	6.4 dBi
Gain Bottom	7.3 dBi
Power	300 W CW (each port)
VSWR	< 1.4:1 maximum
Polarisation	Linear, vertical
Horizontal Beamwidth	360°
Elevation Beamwidth	16.5°, -3 dB point
Electrical Downtilt	6°
Isolation between antennas	< 37 dB
Lightning Protection	Will withstand pulse of 2.5×10^6 A ² s. All metal parts DC grounded
Impedance	50Ω
RF Termination	2 x 7/16 female on cable downloads

Mechanical Characteristics	
Material	GRP shroud Colour White Aluminium mounting section and cap
Dimensions	5780 x 60Ø mm
Weight	12.5 kg
Wind Surface area	0.30m ²
Wind Loading	430 N maximum @ 160 km/hour

General Antenna Information
Normal mounting.

ASCII format radiation patterns are available upon request.

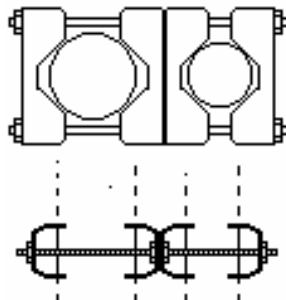

Clamps to fit pipes of 115mmØ



MAT JAYBEAM reserve the right to modify or amend any antenna or specification without prior notice

**Type 7047 TETRA
Base Station Antenna
Omnidirectional 4 stacked dipoles
Upgraded for better Intermodulation figures**



Type Number: 7047 200

This antenna, one of our well-established 4 stack dipoles, has been upgraded to improve intermodulation performance for today's digital PMR systems such as TETRA.

Operating frequency is the TETRA band, (380-430MHz.)

The rugged construction and high quality components used ensure a long and reliable service life.

Electrical Characteristics	7047 200
Frequency	380 – 430 MHz
Max Gain	5.2dBd, 7.3 dBi
Power	200 W CW
VSWR	< 1.5:1 typical
Polarisation	Linear , vertical
Horizontal Beamwidth	360° -3 dB point
Elevation Beamwidth	20° , -3 dB point
Intermodulation Performance	< -145 dBc for 2 x 20watt carriers
Lightning Protection	All metal parts DC grounded
Impedance	50Ω
RF Termination	7/16 female on RG214 Downlead.

Typical Radiation Pattern (E Plane)

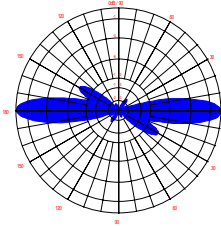

Typical Radiation Pattern (H Plane)

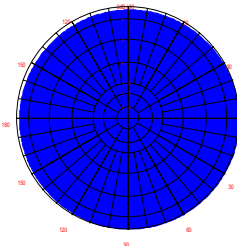

Mechanical Characteristics	
Construction	Centre fed folded dipoles, (with baluns) fixed on a one piece vertical boom. Dipoles are able to be rotated on the boom to allow for omni or directional mode.
Dimensions	2600 x 132 x 110 mm
Weight	7.0 kg
Wind Surface area	0.14m ²
Wind Loading	190 N maximum @ 45m/sec

General Antenna Information

Normal mounting.
Either clamped at bottom, or fixed top and bottom, stood off the side of a radio mast.
Will also drop into a standard size (48.4mm) scaffolding pole.

ASCII format radiation patterns are available upon request.



Jaybeam reserve the right to modify or amend any antenna or specification without prior notice

Type 7148 TETRA
Directional 4 stacked dipoles
Upgraded intermodulation performance
Lightning Proof, 0° Beam Tilt option.



Typical Radiation Pattern (E Plane)

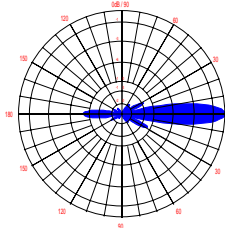

Typical Radiation Pattern (H Plane)

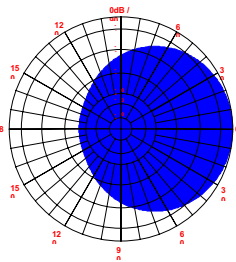

Type Number: 7148 200

This antenna, one of our well-established 4 stack dipoles, has been upgraded to improve intermodulation performance for today's digital PMR systems such as TETRA.

Operating frequency is the TETRA band, (380-430MHz.)

The rugged construction and high quality components used ensure a long and reliable service life.

Electrical Characteristics	7148 200
Frequency	380 – 430 MHz
Max Gain (directional)	9.0dBd, 11.0 dBi
Power	200 W CW
VSWR	< 1.5:1 typical
Polarisation	Linear , vertical
Horizontal Beamwidth	160° -3 dB point
Elevation Beamwidth	17° , -3 dB point
Intermodulation Performance	< -143 dBc for 2 x 20watt carriers
Electrical Downtilt	0°
Lightning Protection	All metal parts DC grounded

Impedance	50Ω
RF Termination	7/16 DIN female on RG214 Downlead.

Mechanical Characteristics	
Construction	Centre fed folded dipoles, (with baluns) fixed on a one piece vertical boom. Dipoles are able to be rotated on the boom to allow for omni or directional mode.
Dimensions	2600 x 132 x 110 mm
Weight	7.0 kg
Wind Surface area	0.14m ²
Wind Loading	190 N maximum @ 45m/sec

General Antenna Information

Normal mounting.

Either clamped at bottom, or fixed top and bottom, stood off the side of a radio mast.

Will also drop into a standard size (48.4mm) scaffolding pole.

ASCII format radiation patterns are available upon request.

MAT JAYBEAM reserve the right to modify or amend any antenna or specification without prior notice

Type 7148 TETRA
Directional 4 stacked dipoles
Upgraded intermodulation performance
Lightning Proof, 5° Beam Tilt option.



Typical Radiation Pattern (E Plane)

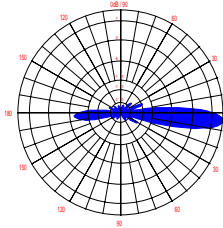

Typical Radiation Pattern (H Plane)

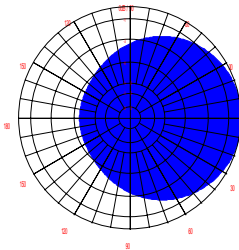

Type Number: 7148 205

This antenna, one of our well-established 4 stack dipoles, has been upgraded to improve intermodulation performance for today's digital PMR systems such as TETRA.

Operating frequency is the TETRA band, (380-430MHz.)

The rugged construction and high quality components used ensure a long and reliable service life.

Electrical Characteristics	7148 205
Frequency	380 – 430 MHz
Max Gain (directional)	9.0dBd, 11.0 dBi
Power	200 W CW
VSWR	< 1.5:1 typical
Polarisation	Linear , vertical
Horizontal Beamwidth	160° -3 dB point
Elevation Beamwidth	17° , -3 dB point
Intermodulation Performance	< -143 dBc for 2 x 20watt carriers
Electrical Downtilt	5°
Lightning Protection	All metal parts DC grounded

Impedance	50Ω
RF Termination	7/16 DIN female on RG214 Downlead.

Mechanical Characteristics	
Construction	Centre fed folded dipoles, (with baluns) fixed on a one piece vertical boom. Dipoles are able to be rotated on the boom to allow for omni or directional mode.
Dimensions	2600 x 132 x 110 mm
Weight	7.0 kg
Wind Surface area	0.14m ²
Wind Loading	190 N maximum @ 45m/sec

General Antenna Information

Normal mounting.
Either clamped at bottom, or fixed top and bottom, stood off the side of a radio mast.
Will also drop into a standard size (48.4mm) scaffolding pole.

ASCII format radiation patterns are available upon request.

MAT JAYBEAM reserve the right to modify or amend any antenna or specification without prior notice

Type 7148 TETRA
Directional 4 stacked dipoles
Upgraded intermodulation performance
Lightning Proof, 10° Beam Tilt option.



Typical Radiation Pattern (E Plane)

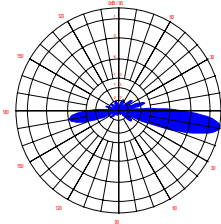

Typical Radiation Pattern (H Plane)

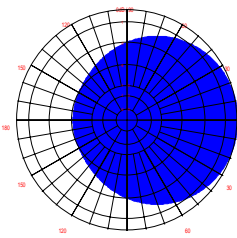

Type Number: 7148 210

This antenna, one of our well-established 4 stack dipoles, has been upgraded to improve intermodulation performance for today's digital PMR systems such as TETRA.

Operating frequency is the TETRA band, (380-430MHz.)

The rugged construction and high quality components used ensure a long and reliable service life.

Electrical Characteristics	7148 210
Frequency	380 – 430 MHz
Max Gain (directional)	9.0dBd, 11.0 dBi
Power	200 W CW
VSWR	< 1.5:1 typical
Polarisation	Linear , vertical
Horizontal Beamwidth	160° -3 dB point
Elevation Beamwidth	17° , -3 dB point
Intermodulation Performance	< -143 dBc for 2 x 20watt carriers
Electrical Downtilt	10°
Lightning Protection	All metal parts DC grounded

Impedance	50Ω
RF Termination	7/16 DIN female on RG214 Downlead.

Mechanical Characteristics	
Construction	Centre fed folded dipoles, (with baluns) fixed on a one piece vertical boom. Dipoles are able to be rotated on the boom to allow for omni or directional mode.
Dimensions	2600 x 132 x 110 mm
Weight	7.0 kg
Wind Surface area	0.14m ²
Wind Loading	190 N maximum @ 45m/sec

General Antenna Information

Normal mounting.

Either clamped at bottom, or fixed top and bottom, stood off the side of a radio mast.

Will also drop into a standard size (48.4mm) scaffolding pole.

ASCII format radiation patterns are available upon request.



MAT JAYBEAM reserve the right to modify or amend any antenna or specification without prior notice

Type 7014
UHF 12 Element Yagi, TETRA
High Gain end mounted.
Upgraded for enhanced IMP



Type Number 7014 385

A 12-element yagi antenna long established in our range.

Ideal for repeaters and fixed mobile use, it has a superb radiation pattern and has been carefully optimised to give ultimate performance for this type. This version has upgraded intermodulation performance for modern TETRA systems.

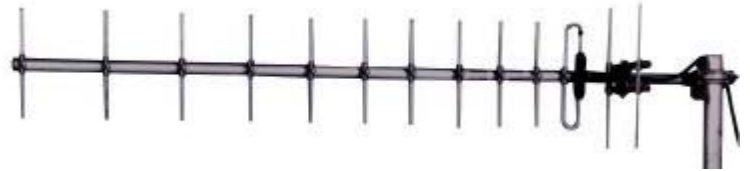

Typical Radiation Pattern (H Plane)

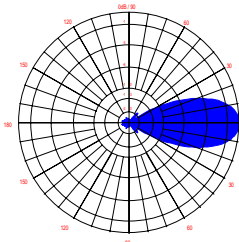

Typical Radiation Pattern (E Plane)

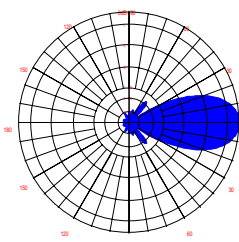

Electrical Characteristics	7014 385
Frequency	380 – 400 MHz
Bandwidth	± 4% (typical)
Gain (max)	12.0 dBd (14.2dBi)
Power	150 Watts
VSWR	< 1.5:1 typical
Polarisation	Linear, Vertical or Horizontal
‘H’ Plane Beamwidth	36°, -3 dB point
‘E’ Plane Beamwidth	40°, -3 dB point
Front to Back Ratio	>25dB (typical)
Impedance	50Ω
Terminations	7/16 DIN female, on 3m download of RG214 Coaxial Cable
3 rd order intermod figures	< -145dBc for 2 x 10watt carriers
All antennas are DC Grounded	

Mechanical Characteristics	
Material	Boom, 32mmØ Aluminium Elements, 12.5mmØ Drawn Aluminium tube. Balun, Inverse type, moulded.
Length	2420 mm
Weight	5.2 kg excluding mounting hardware.
Wind Loading	145 N maximum @ 45m/sec
	Rv0403

General Antenna Information
ASCII format radiation patterns are available upon request.

Mounting Accessories:
Recommended clamps:
9078/9, 9174, 9112 or 99364
(fits 50mm or 75mm poles)



MAT JAYBEAM reserve the right to modify or amend any antenna or specification without prior notice

Jaybeam Limited
 Rutherford Drive, Park Farm South, Wellingborough,
 Northamptonshire, NN8 6AX, England
 Tel: +44 (0) 1933 408408 Fax: +44 (0) 1933 408404
 WWW.JAYBEAM.CO.UK

MAT Equipment
 ZI La Boitardiere – Chemin du Roy
 37400 Amboise - France
 Tel: +33 (0) 2 4730 6970 Fax: +33 (0) 2 4757 3506
 WWW.MATEQUIPEMENT.COM

Type 7043
UHF 8 Element Yagi, TETRA
High Gain end mounted.
Upgraded for enhanced IMP



Type Number 7043 385

An 8-element yagi antenna long established in our range.

It offers the ultimate performance for this type and carries UK R.A. approval to MPT1411 for UHF Telemetry systems.

Strong and easily mounted, it is also highly suited to modern digital systems such as TETRA.



Typical Radiation Pattern (H Plane)

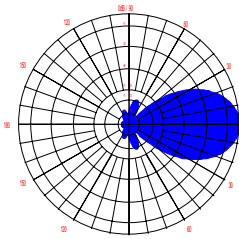

Typical Radiation Pattern (E Plane)

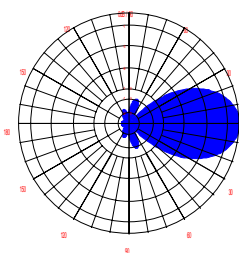

Electrical Characteristics	7043 385
Frequency	380 – 400 MHz
Bandwidth	± 4% (typical)
Gain (max)	10.0 dBd (12.2dBi)
Power	150 Watts
VSWR	< 1.5:1 typical
Polarisation	Linear, Vertical or Horizontal
‘H’ Plane Beamwidth	54°, -3 dB point
‘E’ Plane Beamwidth	45°, -3 dB point
Front to Back Ratio	>22dB (typical)
Impedance	50Ω
Terminations	7/16 DIN female, on 3m download of RG214 Coaxial Cable
3 rd order intermod figures	< -145dBc for 2 x 10watt carriers
All antennas are DC Grounded	

Mechanical Characteristics	
Material	Boom, 32mmØ Aluminium Elements, 12.5mmØ Drawn Aluminium tube. Balun, Inverse type, moulded.
Length (@450MHz)	1270 mm
Weight (@450MHz)	4.0 kg excluding mounting hardware.
Wind Loading (@450MHz)	92 N maximum @ 45m/sec
	Rv0403

General Antenna Information

ASCII format radiation patterns are available upon request.

Mounting Accessories:

Recommended clamps:
9078/9, 9174, 9112 or
99364
(fits 50mm or 75mm poles)



MAT JAYBEAM reserve the right to modify or amend any antenna or specification without prior notice

Type 7042 385
UHF 6 Element Yagi
High Gain end mounted.
Upgraded IMP version for TETRA



Type Number 7042 385

A 6-element yagi antenna with upgraded IMP. This version has been developed for ultimate performance for this type and is highly suited to a 'fixed mobile' antenna where some directivity is required. Strong and easily mounted, it is highly suited to modern digital systems such as TETRA.



Typical Radiation Pattern (H Plane)

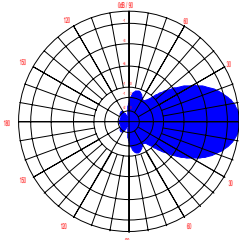

Typical Radiation Pattern (E Plane)

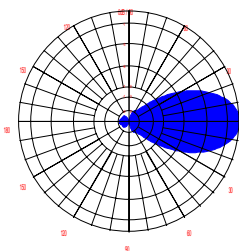

Electrical Characteristics	7042 385
Frequency band	380 – 400 MHz
Gain (max)	8.5 dBd (10.65dBi)
Power	150 Watts
VSWR	< 1.5:1 typical
Polarisation	Linear, Vertical or Horizontal
'H' Plane Beamwidth	56°, -3 dB point
'E' Plane Beamwidth	46°, -3 dB point
Front to Back Ratio	>22dB (typical)
3 rd Order Intermodulation	< - 145dBc with 2 x 10 watt carriers
Impedance	50Ω
Terminations	7/16 type female, on 3m download of RG214 Coaxial Cable

All antennas are DC Grounded

Mechanical Characteristics	
Material	Boom, 32mmØ Aluminium Elements, 12.5mmØ Drawn Aluminium tube. Balun, Inverse type, moulded.
Length	1112 mm
Weight	3.5 kg excluding mounting hardware.
Wind Loading	95 N maximum @ 45m/sec

General Antenna Information

Mounting Accessories:
Recommended clamps:
9078/9, 9174, 9112 or
99364
(fits 50mm or 75mm poles)

ASCII format radiation patterns are available upon request.

Type 7041
UHF 4 Element Yagi
High Gain end mounted.
Upgraded IMP version for TETRA



Type Number 7041 385

A 4-element yagi antenna with upgraded IMP.

This version has been developed for ultimate performance for this type and is highly suited to a 'fixed mobile' antenna where some directivity is required.

Strong and easily mounted, it is highly suited to modern digital systems such as TETRA.



Typical Radiation Pattern (H Plane)

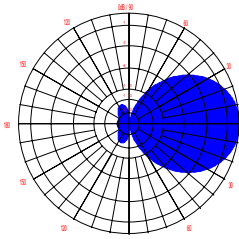

Typical Radiation Pattern (E Plane)

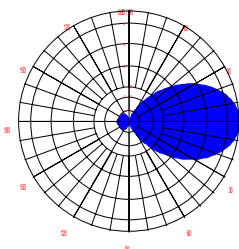

Electrical Characteristics	7041 385
Frequency band	380 – 400 MHz
Gain (max)	7.5 dBd (9.65dBi)
Power	150 Watts
VSWR	< 1.5:1 typical
Polarisation	Linear, Vertical or Horizontal
'H' Plane Beamwidth	78°, -3 dB point
'E' Plane Beamwidth	58°, -3 dB point
Front to Back Ratio	>19dB (typical)
3 rd Order Intermodulation	< - 145dBc with 2 x 10 watt carriers
Impedance	50Ω
Terminations	7/16 type female, on 3m download of RG214 Coaxial Cable

All antennas are DC Grounded

Mechanical Characteristics	
Material	Boom, 32mmØ Aluminium Elements, 12.5mmØ Drawn Aluminium tube. Balun, Inverse type, moulded.
Length	770 mm
Weight	2.5 kg excluding mounting hardware.
Wind Loading	69 N maximum @ 45m/sec

General Antenna Information

Mounting Accessories:
Recommended clamps:
9078/9, 9174, 9112 or
99364
(fits 50mm or 75mm poles)

ASCII format radiation patterns are available upon request.

Type 7040
UHF 3 Element Yagi
High Gain end mounted.
Upgraded for enhanced IMP



Type Number 7040 385

A 3-element yagi antenna long established in our range.

It offers the ultimate performance for this type and is highly suited to a 'fixed mobile' antenna where some directivity is required.

This version has upgraded intermodulation performance for modern TETRA systems



Typical Radiation Pattern (H Plane)

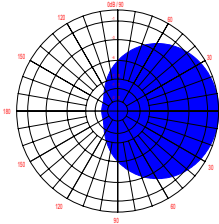

Typical Radiation Pattern (E Plane)

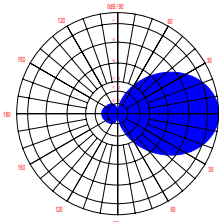

Electrical Characteristics	7040 385
Frequency	380 – 400 MHz
Bandwidth	± 5% (typical)
Gain (max)	5.0 dBd (7.2dBi)
Power	150 Watts
VSWR	< 1.5:1 typical
Polarisation	Linear, Vertical or Horizontal
'H' Plane Beamwidth	120°, -3 dB point
'E' Plane Beamwidth	70°, -3 dB point
Front to Back Ratio	>15dB (typical)
Impedance	50Ω
3 rd Order Intermodulation Terminations	< -145dBc for 2 x 10watt carriers 7/16 DIN type female, on 3m download of RG214 Coaxial Cable

All antennas are DC Grounded

Mechanical Characteristics	
Material	Boom, 32mmØ Aluminium Elements, 12.5mmØ Drawn Aluminium tube. Balun, Inverse type, moulded.
Length	650 mm
Weight	1.7 kg excluding mounting hardware.
Wind Loading	60 N maximum @ 45m/sec

General Antenna Information

Mounting Accessories:

Recommended clamps:
9078/9, 9174, 9112 or 99364
(fits 50mm or 75mm poles)

ASCII format radiation patterns are available upon request.



MAT JAYBEAM reserve the right to modify or amend any antenna or specification without prior notice

Type 7039
UHF 2 Element Yagi
End mounted.
Upgraded for enhanced IMP



Type Number 7039 385

A 2-element yagi antenna long established in our range.

It offers the ultimate performance for this type and is highly suited to a 'fixed mobile' antenna where some directivity is required.

This version has upgraded intermodulation performance for modern TETRA systems



Typical Radiation Pattern (H Plane)

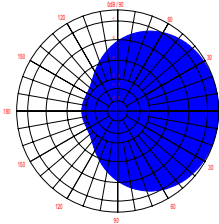

Typical Radiation Pattern (E Plane)

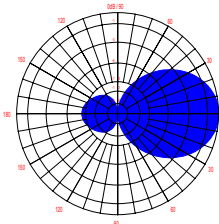

Electrical Characteristics	7039 385
Frequency	380 – 400 MHz
Bandwidth	± 5% (typical)
Gain (max)	3.0 dBd (5.2dBi)
Power	150 Watts
VSWR	< 1.5:1 typical
Polarisation	Linear, Vertical or Horizontal
'H' Plane Beamwidth	150°, -3 dB point
'E' Plane Beamwidth	75°, -3 dB point
Front to Back Ratio	>12dB (typical)
Impedance	50Ω
3 rd order Intermodulation Terminations	< -145dBc with 2 x 20watt carriers 7/16 type female, on 3m download of RG214 Coaxial Cable

All antennas are DC Grounded

Mechanical Characteristics	
Material	Boom, 32mmØ Aluminium Elements, 12.5mmØ Drawn Aluminium tube. Balun, Inverse type, moulded.
Length	590 mm
Weight	1.5 kg excluding mounting hardware.
Wind Loading	53 N maximum @ 45m/sec

General Antenna Information

ASCII format radiation patterns are available upon request.

Mounting Accessories:

Recommended clamps:

9078/9, 9174, 9112 or

99364

(fits 50mm or 75mm poles)



MAT JAYBEAM reserve the right to modify or amend any antenna or specification without prior notice

Jaybeam Limited
 Rutherford Drive, Park Farm South, Wellingborough,
 Northamptonshire, NN8 6AX, England
 Tel: +44 (0) 1933 408408 Fax: +44 (0) 1933 408404
 WWW.jaybeam.co.uk

MAT Equipment
 ZI La Boitardiere – Chemin du Roy
 37400 Amboise - France
 Tel: +33 (0) 2 4730 6970 Fax: +33 (0) 2 4757 3506
 WWW.matequipement.com

Type 5043 000
80° Sector TETRA 380-430MHz Band
High Gain Panel
Dual Polarised



Type Number: 5043 000

A High Gain Dual Polarised ($\pm 45^\circ$) Panel, developed for UHF TETRA systems.

Latest construction technology gives the highest performance and excellent reliability, together with an ascetic appearance.

Strong mounting clamps are provided, allowing fitting to poles of up to 115mm \varnothing .

Electrical Characteristics	5043 000
Frequency	380 to 430 MHz
Gain (max)	14.0 dBi
Power	250 W per port
VSWR	< 1.3:1 full band
Polarisation	$\pm 45^\circ$
Horizontal Beamwidth	$80^\circ \pm 5^\circ$ - 3 dB points
Elevation Beamwidth	$19^\circ \pm 1^\circ$ - 3 dB points
Front to Back Ratio	> 24 dB
Isolation between Ports	> 30dB
3 rd order Intermodulation	-153dBc for 2 x 20watt carriers
Electrical Tilt	0°
Impedance	50 Ω
Terminations	2 x 7/16 DIN sockets on the bottom face

Typical Radiation Pattern (E Plane)

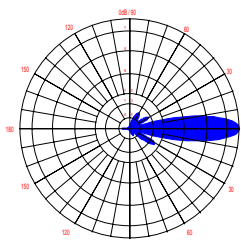

All antennas are DC Grounded

Typical Radiation Pattern (H Plane)

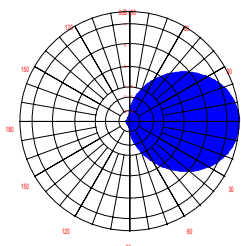

Mechanical Characteristics	
Material	Housing: Aluminium, 'Alocrom' finish. Shroud: Outdoor quality profiled extruded 'Styrosun'
Dimensions	2000 x 400 x 195 mm
Weight	17 kg approximate excluding mounting hardware
Wind Loading	1000 N maximum @ 45m/sec
	Rv0403

General Antenna Information	
Shipping Dimensions	1 carton, 2250 x 600 x 315

Mounting Accessories:

Brackets supplied, fits pipes 48 to 115 mm diameter. Provides 0° to $\pm 10^\circ$ mechanical tilt. Calibrated at 1° intervals.

ASCII format radiation patterns are available upon request.



MAT JAYBEAM reserve the right to modify or amend any antenna or specification without prior notice

Type 5043 010
80° Sector TETRA 380-430MHz Band
High Gain Panel
Dual Polarised 10° Electrical Downtilt



Type Number: 5043 010

A High Gain Dual Polarised ($\pm 45^\circ$) Panel, developed for UHF TETRA systems.

Latest construction technology gives the highest performance and excellent reliability, together with an ascetic appearance.

Strong mounting clamps are provided, allowing fitting to poles of up to 115mm \varnothing .

Electrical Characteristics	5043 010
Frequency	380 to 430 MHz
Gain (max)	14.0 dBi
Power	250 W per port
VSWR	< 1.3:1 full band
Polarisation	$\pm 45^\circ$
Horizontal Beamwidth	$80^\circ \pm 5^\circ$ - 3 dB points
Elevation Beamwidth	$19^\circ \pm 1^\circ$ - 3 dB points
Front to Back Ratio	> 24 dB
Isolation between Ports	> 30dB
3 rd Order Intermodulation	-153 dBc for 2 x 20watt carriers
Electrical Tilt	10°
Impedance	50 Ω
Terminations	2 x 7/16 DIN sockets on the bottom face.

Typical Radiation Pattern (E Plane)

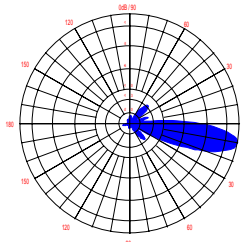

All antennas are DC Grounded

Typical Radiation Pattern (H Plane)

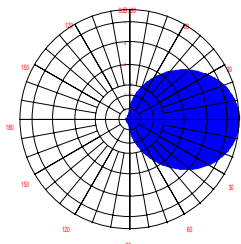

Mechanical Characteristics

Material	Housing: Aluminium, 'Alocrom' finish. Shroud: Outdoor quality profiled extruded 'Styrosun'
Dimensions	2000 x 400 x 195 mm
Weight	17 kg approximate excluding mounting hardware
Wind Loading	1000 N maximum @ 45m/sec
	Rv0403

General Antenna Information

Shipping Dimensions 1 carton, 2250 x 600 x 315

Mounting Accessories:

Brackets supplied, fits pipes 48 to 115 mm diameter. Provides 0° to $\pm 10^\circ$ mechanical tilt. Calibrated at 1° intervals.

ASCII format radiation patterns are available upon request.



MAT JAYBEAM reserve the right to modify or amend any antenna or specification without prior notice

Type 5043 015
80° Sector TETRA 380-430MHz Band
High Gain Panel
Dual Polarised, 15° Electrical Downtilt



Type Number: 5043 015

A High Gain Dual Polarised ($\pm 45^\circ$) Panel, developed for UHF TETRA systems.

Latest construction technology gives the highest performance and excellent reliability, together with an ascetic appearance.

Strong mounting clamps are provided, allowing fitting to poles of up to 115mm \varnothing .

Electrical Characteristics	5043 015
Frequency	380 to 430 MHz
Gain (max)	13.5 dBi
Power	250 W per port
VSWR	< 1.3:1 full band
Polarisation	$\pm 45^\circ$
Horizontal Beamwidth	$80^\circ \pm 5^\circ$ - 3 dB points
Elevation Beamwidth	$20^\circ \pm 1^\circ$ - 3 dB points
Front to Back Ratio	> 24 dB
Isolation between Ports	> 30dB
3 rd order Intermodulation	-153 dBc for 2 x 20watt carriers
Electrical Tilt	15°
Impedance	50 Ω
Terminations	2 x 7/16 DIN sockets on the bottom face.

Typical Radiation Pattern (E Plane)

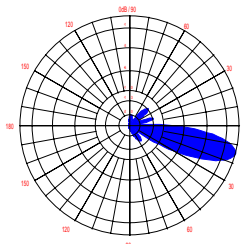

All antennas are DC Grounded

Typical Radiation Pattern (H Plane)

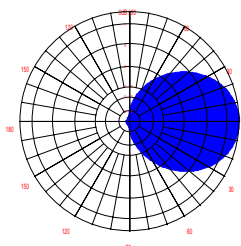

Mechanical Characteristics	
Material	Housing: Aluminium, 'Alocrom' finish. Shroud: Outdoor quality profiled extruded 'Styrosun'
Dimensions	2000 x 400 x 195 mm
Weight	17 kg approximate excluding mounting hardware
Wind Loading	1000 N maximum @ 45m/sec
	Rv0403

General Antenna Information	
Shipping Dimensions	1 carton, 2250 x 600 x 315

Mounting Accessories:

Brackets supplied, fits pipes 48 to 115 mm diameter. Provides 0° to $\pm 10^\circ$ mechanical tilt. Calibrated at 1° intervals.

ASCII format radiation patterns are available upon request.



MAT JAYBEAM reserve the right to modify or amend any antenna or specification without prior notice

Type 5023 010
80° Sector TETRA 380-430MHz Band
Medium Gain Panel
Dual Polarised 10° Electrical Downtilt



Typical Radiation Pattern (E Plane)

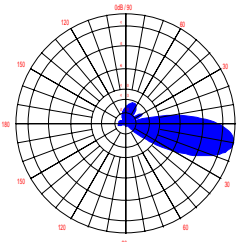

Typical Radiation Pattern (H Plane)

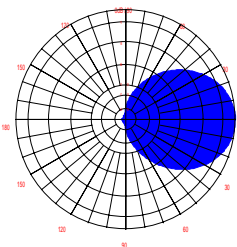

Type Number: 5023 010

A Medium Gain Dual Polarised ($\pm 45^\circ$) Panel, developed for UHF TETRA systems.

Latest construction technology gives the highest performance and excellent reliability, together with an ascetic appearance.

Strong mounting clamps are provided, allowing fitting to poles of up to 115mm \varnothing .

Electrical Characteristics	5023 010
Frequency	380 to 430 MHz
Gain (max)	11.2 dBi
Power	200 W per port
VSWR	< 1.5:1 full band
Polarisation	$\pm 45^\circ$
Horizontal Beamwidth	$80^\circ \pm 5^\circ$ - 3 dB points
Elevation Beamwidth	$28^\circ \pm 1^\circ$ - 3 dB points
Front to Back Ratio	> 24 dB
Isolation between Ports	> 30dB
3 rd Order Intermodulation	-153dBc for 2 x 20watt carriers
Electrical Tilt	10°
Impedance	50 Ω
Terminations	2 x 7/16 DIN sockets on the rear face, facing downwards

All antennas are DC Grounded

Mechanical Characteristics

Material	Housing: Aluminium, 'Alocrom' finish. Shroud: Outdoor quality profiled extruded 'Styrosun' Colour, Stone Grey : RAL 7030
Dimensions	1500 x 400 x 195 mm
Weight	14 kg approximate excluding mounting hardware
Wind Loading	810 N maximum @ 45m/sec Rv0403

General Antenna Information

Mounting Accessories:

Brackets supplied, fits pipes 48 to 115 mm diameter. Provides 0° to $\pm 10^\circ$ mechanical tilt. Calibrated at 1° intervals.

ASCII format radiation patterns are available upon request.



MAT JAYBEAM reserve the right to modify or amend any antenna or specification without prior notice

Type 5023 015
80° Sector TETRA 380-430MHz Band
Medium Gain Panel
Dual Polarised 15° Electrical Downtilt



Typical Radiation Pattern (E Plane)

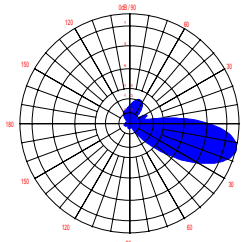

Typical Radiation Pattern (H Plane)

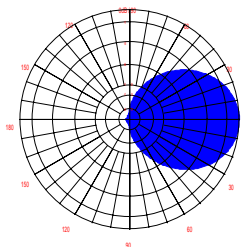

Type Number: 5023 015

A Medium Gain Dual Polarised ($\pm 45^\circ$) Panel, developed for UHF TETRA systems.

Latest construction technology gives the highest performance and excellent reliability, together with an ascetic appearance.

Strong mounting clamps are provided, allowing fitting to poles of up to 115mm \varnothing .

Electrical Characteristics	5023 015
Frequency	380 to 430 MHz
Gain (max)	11.2 dBi
Power	200 W per port
VSWR	< 1.5:1 full band
Polarisation	$\pm 45^\circ$
Horizontal Beamwidth	$80^\circ \pm 5^\circ - 3 \text{ dB points}$
Elevation Beamwidth	$28^\circ \pm 1^\circ - 3 \text{ dB points}$
Front to Back Ratio	> 24 dB
Isolation between Ports	> 30dB
3 rd Order Intermodulation	-153dBc for 2 x 20watt carriers
Electrical Tilt	15°
Impedance	50 Ω
Terminations	2 x 7/16 DIN sockets on the rear face, facing downwards

All antennas are DC Grounded

Mechanical Characteristics

Material	Housing: Aluminium, 'Alocrom' finish. Shroud: Outdoor quality profiled extruded 'Styrosun' Colour Stone Grey : RAL 7030
Dimensions	1500 x 400 x 195 mm
Weight	14 kg approximate excluding mounting hardware
Wind Loading	810 N maximum @ 45m/sec Rv0403

General Antenna Information

Mounting Accessories:

Brackets supplied, fits pipes 48 to 115 mm diameter. Provides 0° to $\pm 10^\circ$ mechanical tilt. Calibrated at 1° intervals.

ASCII format radiation patterns are available upon request.



MAT JAYBEAM reserve the right to modify or amend any antenna or specification without prior notice



Type Number: 5049 400

A High Gain Linear Polarised Panel, developed for UHF TETRA systems.

Latest construction technology gives the highest performance and excellent reliability, together with an ascetic appearance.

Strong mounting clamps are provided, allowing fitting to poles of up to 115mm Ø.

Electrical Characteristics	5049 400
Frequency	380 to 430 MHz
Gain (max)	14.0 dBi
Power	250 Watts
VSWR	< 1.4:1 full band
Polarisation	Linear, Vertical
Horizontal Beamwidth	92° ± 4° - 3 dB points
Elevation Beamwidth	19° ± 1° - 3 dB points
Front to Back Ratio	> 22 dB
3 rd Order Intermodulation	-153dBc for 2 x 20watt carriers
Electrical Tilt	0°
Impedance	50 Ω
Terminations	7/16 DIN socket on the lower face, facing downwards

All antennas are DC Grounded

Typical Radiation Pattern (E Plane)

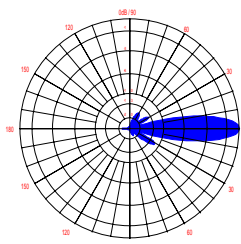

Typical Radiation Pattern (H Plane)

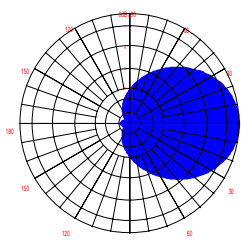

Mechanical Characteristics	
Material	Housing: Aluminium, 'Alocrom' finish. Shroud: Outdoor quality profiled extruded 'Styrosun'
Dimensions	2000 x 400 x 195 mm
Weight	17 kg approximate excluding mounting hardware
Wind Loading	1000 N maximum @ 45m/sec Rv0403

General Antenna Information	
Shipping Dimensions	1 carton, 2250 x 600 x 315 GW 29kg

Mounting Accessories:

Brackets supplied, fits pipes 48 to 115 mm diameter. Provides 0° to ± 10° mechanical tilt. Calibrated at 1° intervals.

ASCII format radiation patterns are available upon request.



Jaybeam reserve the right to modify or amend any antenna or specification without prior notice

Type Number: **5004 380**

A High Quality Sector antenna that has adjustable horizontal beamwidth from 90° through 120°, 140° to 180°.

It is chiefly used in a pair mounted on a large face width radio tower to give near omnidirectional coverage.

Jaybeam can give predicted radiation patterns against customers requests.

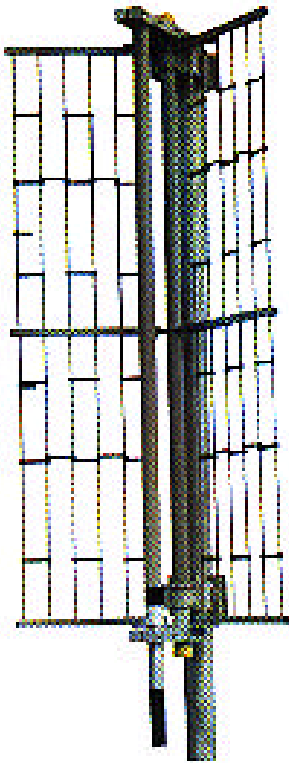

Electrical Characteristics		5004 380
Frequency		380 – 400 MHz
Gain (dBd)		9.3 @ 90°, 8.4 @120°, 7.4 @140°, 6.3 @ 180°
Power		250 Watts CW
VSWR		< 1.5:1
Polarisation		Linear, Vertical
Horizontal Beamwidth (- 3dB point)		Adjustable to 90°, 120°, 140° & 180°
Vertical Beamwidth (- 3dB point)		19°
Front to Back Ratio		25 @ 90°, 22 @120°, 20.6 @140°, 17.3 @ 180°
Impedance		50Ω
Terminations		7/16 DIN female fixed in base of radiating element
Intermodulation Figure All antennas are DC Grounded		< -148dBc for 2x20watt carriers
Mechanical Characteristics		
Construction		'Radiator element sealed in glass fibre tube, Reflector assembly in high grade aluminium, polyester coated.
Dimensions		2600 x 800 x 400 mm
Weight		16.0 kg excluding mounting hardware.
Wind Loading Rv0403		800 N maximum @ 160 km/hour

General Antenna Information

Mounting details	Optional steel brackets to fit pipes of 48-115mm\varnothing and providing mechanical tilt up to 15° at 1° intervals.
Weight of mounting brackets	8.1kg.

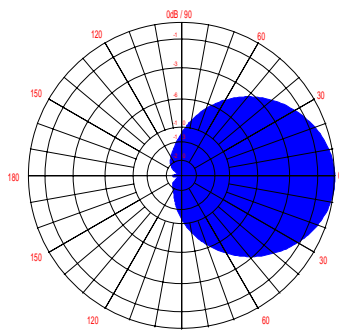

Typical Radiation Pattern (H Plane) 90°

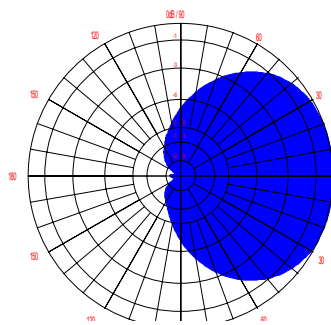

Typical Radiation Pattern (H Plane) 140°

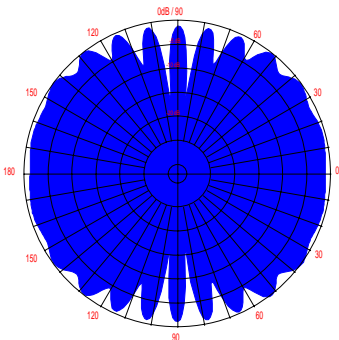

Typical Radiation Pattern (H Plane) 2x Antennas 3.0m apart, 180° angle between

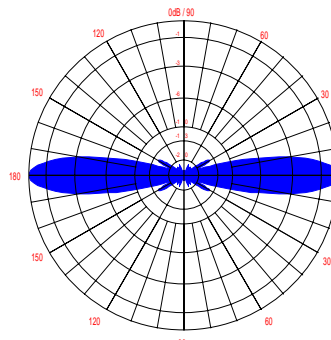

Typical Radiation Pattern (E Plane) 2x Antennas 3.0m apart, 180° angle between.

ASCII Format Radiation Patterns are available upon request. [CLICK HERE !](#)
Please contact Jaybeam Technical Sales



**TETRA Band Adjustable Corner Reflector
Horizontal Beam, 90°, 120°, 140° & 180°
Sector Antenna, Linear Polarisation 10° Tilt
Used as 'Building Block' for Omni coverage**



Type Number: **5004 390**

A High Quality Sector antenna that has adjustable horizontal beamwidth from 90° through 120°, 140° to 180°.

It is chiefly used in a pair mounted on a large face width radio tower to give near omnidirectional coverage.

Jaybeam can give predicted radiation patterns against customers requests.



Electrical Characteristics		5004 390
Frequency		380 – 400 MHz
Gain (dBd)		9.3 @ 90°, 8.4 @ 120°, 7.4 @ 140°, 6.3 @ 180°
Power		250 Watts CW
VSWR		< 1.5:1
Polarisation		Linear, Vertical
Horizontal Beamwidth (- 3dB point)		Adjustable to 90°, 120°, 140° & 180°
Vertical Beamwidth (- 3dB point)		19°
Front to Back Ratio		25 @ 90°, 22 @ 120°, 20.6 @ 140°, 17.3 @ 180°
Electrical Beam Tilt		10°
Impedance		50Ω
Terminations		7/16 DIN female fixed in base of radiating element
Intermodulation Figure <small>All antennas are DC Grounded</small>		< -148dBc for 2x20watt carriers
Mechanical Characteristics		
Construction		'Radiator element sealed in glass fibre tube, Reflector assembly in high grade aluminium, polyester coated.
Dimensions		2600 x 800 x 400 mm
Weight		16.0 kg excluding mounting hardware.
Wind Loading		800 N maximum @ 160 km/hour
		<small>Rv0304</small>

General Antenna Information	
Mounting details	Optional steel brackets to fit pipes of 48-115mmØ and providing mechanical tilt up to 15° at 1° intervals .
Weight of mounting brackets	8.1kg.

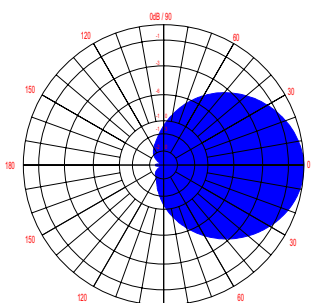

Typical Radiation Pattern (H Plane) 90°

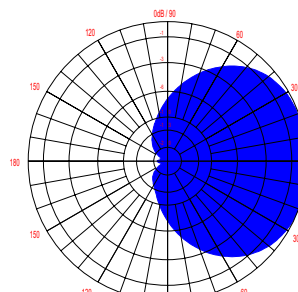

Typical Radiation Pattern (H Plane) 140°

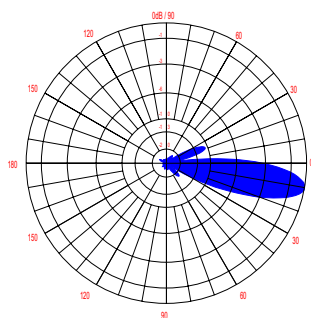

Typical Radiation Pattern (E Plane) 90deg

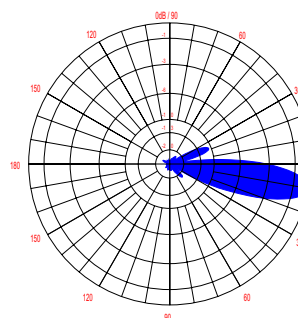

Typical Radiation Pattern (E Plane) 140deg

ASCII Format Radiation Patterns are available upon request.
Please contact Jaybeam Technical Sales



MAT JAYBEAM reserve the right to modify or amend any antenna or specification without prior notice

Jaybeam Limited
 Lutterford Drive, Park Farm South, Wellingborough,
 Northamptonshire, NN8 6AX, England
 Tel: +44 (0) 1933 408408 Fax: +44 (0) 1933 408404
 WWW.jaybeam.co.uk

MAT Equipment
 ZI La Boitardiere – Chemin du Roy
 37400 Amboise - France
 Tel: +33 (0) 2 4730 6970 Fax: +33 (0) 2 4757 3506
 WWW.matequipement.com

**Type 5047 000
TETRA Band Microcell Antenna
Indoor (Fire Retardant) & Outdoor
Wall Mounted**



Type Number: 5047 000

**A useful Microcell antenna for the UHF TETRA Band. (380-400MHz)
Designed for wall mounting it can be used indoors (LS0H materials) or outdoors. (IP66)**

**Only high quality components are used to give optimum performance,
particularly regarding intermodulation, for such a compact antenna**

Electrical Characteristics	5047 000
Frequency	380 – 400 MHz
Gain	4.5 dBi (on typical wall surface)
Power	50 W
VSWR	< 1.5:1
Polarisation	Vertical
Horizontal Beamwidth	Typically 106°, -3 dB points
Front to Back Ratio	>10 dB
Elevation Beamwidth	Typically 112°, -3 dB points
Lightning Protection	Direct ground all conductive components
Impedance	50Ω
Intermodulation	3 rd order – minimum –100dBm with 2 x 5 watt carriers.
Terminations	500 mm RG303 cable, FEP outer jacket, PTFE dielectric, terminated in 'N' socket Cable can be routed downwards, backwards or upwards

Typical Radiation Pattern (E Plane)

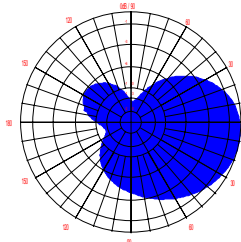

Typical Radiation Pattern (H Plane)

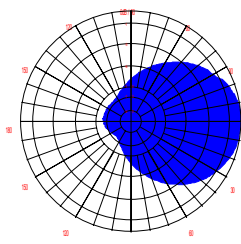

All antennas are DC Grounded

Mechanical Characteristics	
Material	Aluminium housing, Alocrom finish, Stainless steel mounting plate. Shroud, UV Resistant, Halogen free FR ABS Colour White UL94V-O, CAA No.8 Sec 2.2b FAR 25.853b
Dimensions	305 x 225 x 60 mm
Weight	1.05 kg
Wind Loading	85 N maximum @ 160 km/hour

Mounting Arrangement:

Stainless Steel back plate is fixed to wall via 4 screw holes.
Antenna is then clipped onto the backplate giving a secure and unobtrusive mounting.

ASCII format radiation patterns are available upon request.

JAYBEAM reserve the right to modify or amend any antenna or specification without prior notice

Jaybeam Limited

Rutherford Drive, Park Farm South, Wellingborough,
Northamptonshire, NN8 6AX, England
Tel: +44 (0) 1933 408408 Fax: +44 (0) 1933 408404
www.jaybeam.co.uk

MAT Equipment

17 bis, rue du Chemin Vert, 94100
Saint Maur Des Fosses, Paris, France
Tel: +33 (0) 1 55961010 Fax: +33 (0) 1 55960100
www.matequipment.com



MA521P00

MA521P00 is a shrouded low profile omnidirectional antenna intended for indoor coverage by ceiling installation. It is fitted with a 0.5 meter coaxial cable and a N female connector



TECHNICAL DATA :

Product code	MA521P00
Frequency range	380 to 400 MHz
Nominal impedance	50 ohms
VSWR	≤ 2
Polarisation	linear, vertical
Gain	0 dBi (at connector level))
Radiation in horizontal plane	omnidirectional within ± 0.5 dB
Radiation in vertical plane	beamwidth (E plane) at -3 dB : ≈ 80°
Maximum power	3 watts
Connection	at the back of the antenna, by a 0.5 meter RG58 black coaxial cable with N female connector at the end
Dimension	height : ≈ 70 mm diameter: ≈ 204 mm
Weight	≈ 470 g
Materials / colours	shroud : white plastic back plate : aluminium, natural
Grounding	All the metallic parts of the antenna are DC connected to the connector ground, including the inner conductor of the connector and the back plate.
Installation	By three holes with the screws and wall plugs supplied with the antenna. Three white caps are supplied to hide the screws after installation.

Note : Metal in the ceiling structure affects the antenna. On a fully metallic ceiling, maximum VSWR is 2.3 and radiation is totally downwards.

Typical radiation in **horizontal plane** :

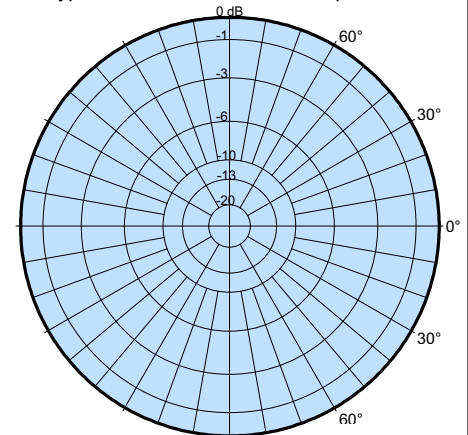

Typical radiation in **vertical plane** :
(in free space antenna facing downwards or on non metallic ceiling)

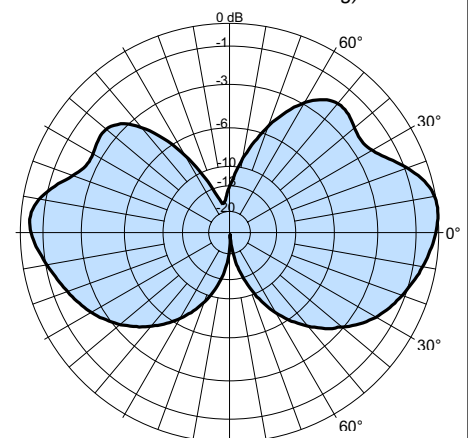



'Norstel' type clamps

All made from galvanised drop forged steel. Made to fit Scaffold poles (48.4mmØ), use in conjunction with increasing sleeves (below) to fit antenna booms.

9078

Fixed 90° double coupler.

9075

1/2 Norstel, c/w bolt for fixing through a plate.

9077

Swivelling double coupler. (please note, cannot be locked into position)



Increasing sleeves

To fit antenna booms and enable clamping with norstel clamps (above).

9174

fits 1" (25.4mm) Ø booms

9079

Fits 1 ¼" (32mm)Ø
(our most popular size)

9719

Fits 1 ½"(38mm)Ø



9894
(was JBL73)

Good strong clamp
Fits 1 ¼" booms to up
To 2" (50mm) poles



9112

Standard cross over plate
Will fit 32 & 38mm
antenna booms to 50 &
60mm poles.
(confirm sizes when
ordering)



9016
Medium duty,
Fits 1 ¼" (32mm) booms
to up to 2" (50mm)
Poles.



9891
(was JBL63)
Medium-light duty fits
25mm-50mm sizes both
ways and can be used as a
parallel clamp as well.

ANTENNA MOUNTING HARDWARE



99364
Circular cast alloy clamp, gives good two point fixing.
Supplied with 2x50mm SS 'U' bolts and '1/2' moon castings to fit antenna booms of 25mm to 50mmØ
Order either 50mm or 75mm U bolts separately to fit poles.



99284
Rectangular cast alloy clamp, gives good two point fixing.
Supplied with 2x50mm SS 'U' bolts and '1/2' moon castings to fit antenna booms of 25mm to 50mmØ
Order either 50/75/100/125mm U bolts separately to fit poles.



99285
Heavy Duty cast alloy crossover clamp, will accommodate tube sizes up to 115mm Ø



99366
Strong square cast alloy clamp, Fits up to 50mm pipes as a crossover or parallel clamp.
Supplied with U bolts.



99365
Rectangular cast alloy clamp similar to 99284 but with facility for tilting, ($\pm 5^\circ$) to allow for rake of a tower.

Order either 50/75/100mm U bolts separately to fit poles



9864
Originally designed for our range of colinear antennas this clamp fits 1 1/4" (32mm) vertically to poles or rails of up to 2" (50mm)

Parallel Clamps



9099
Galvanised steel throughout, fits pipes from 32mm to 60mm Ø.

99235
Similar to 9099 but fits pipes from 48mm to 76mmØ.

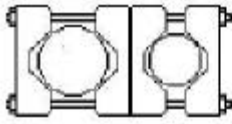

Colinear Clamp
to fit up to 115mm
Part No.
0900638/00

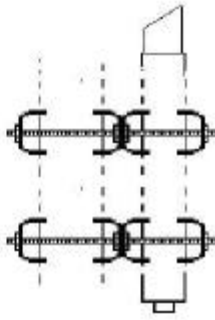

0900638/00

Parallel clamp suitable for fixing Antennas / Poles of 48mm Ø (min) to mounting poles of up to 115mmØ



AJ

Heavy Duty wall stand off brackets made from welded steel angle, hot dip galvanised.

Available in the following sizes:

AJ 9 9" (225mm) stand off.

AJ 12 12" (300mm) stand off.

AJ 15 15" (381mm) stand off.

AJ 18 18" (450mm) stand off.



24" Wall Bracket WD24HD

Made from galvanised steel flat, gives 24" (600mm) stand off.



18" Wall Bracket W21

Made from welded steel angle (galvanised)
Gives 18" (450mm) stand off.



4" & 6" Wall brackets

Made from galvanised steel channel.

9749 Gives 4" (100mm) stand off.

9750 Gives 6" (150mm) stand off.

Both types are supplied with 1x U bolt and 1 x Rawlbolt.



Steel Fixings

A comprehensive range of fixings can be supplied, U bolts, J, V, N and rectangular and others.

All in either galvanised or stainless steel.



Universal tower cleats

9110

Supplied with 1 U bolt

9476

Double U bolts

9443

48.5mm Ø Stub welded

NB

'J' bolts need to be ordered separately

J6 6" (150mm) J bolt fits angle of 50-90mm

J8 8" (200mm) J bolt fits angle of 60-130mm

J10 10" (250mm) J bolt fits angle of 90-180mm



Cable and Connectors

A comprehensive range of Low Loss feeder cable and accessories are available.**

Connectors, grounding kits, fixing clamps etc.

All of high quality at competitive prices.

**** See separate catalogue for 'Hyperflex' range.**



Jaybeam Limited

Rutherford Drive, Park Farm South, Wellingborough,
Northamptonshire, NN8 6AX, England

Tel: +44 (0) 1933 408408 Fax: +44 (0) 1933 408404

WWW.jaybeam.co.uk

MAT Equipement

ZI La Boitardiere - Chemin du Roy
37400 Amboise - France

Tel: +33 (0) 2 4730 6970 Fax: +33 (0) 2 4757 3506

WWW.matequipement.com